

# Ontario Provincial Land Ambulance and Emergency Response Vehicle Standard

VERSION 7.0

Comes into force November 1, 2025

Emergency Health Regulatory and Accountability Branch

## Ontario Provincial Land Ambulance and Emergency Response Vehicle Standard Change Log

<u>Effective Date</u>	<u>OPLA&amp;ERVS Version</u>	<u>Section(s) Updated</u>	<u>Description of Change</u>
November 1, 2025	7.0	3.7	Added clean electrical source to protect sensitive equipment
November 1, 2025	7.0	11 A4	Add requirement to ensure clear line of sight
November 1, 2025	7.0	14.3	Changed to Action Area(s)
November 1, 2025	7.0	16	Update to labelling requirements
November 1, 2025	7.0	19 A9	Increased testing and certification expiry dates to four (4) year initial certification
November 1, 2025	7.0	20	Clarified Professional Engineer requirement in Ontario.
November 1, 2023	6.1		Change log add
November 1, 2023	6.1	14.7 20.20 Annex C Annex D	Section(s) added to re-establish incubator tie down requirements and testing criteria
November 1, 2023	6.1	20.12.3.1(1) 20.12.3.1(3)	Requirements changed from 1034 kPa to 552 kPa to match industry practice and operate within limitation of outlets installed



# ONTARIO PROVINCIAL LAND AMBULANCE and EMERGENCY RESPONSE VEHICLE STANDARD

## Table of Contents

<b>1. SCOPE OF THE STANDARD .....</b>	<b>9</b>
<b>2. DEFINITIONS.....</b>	<b>9</b>
<b>3. GENERAL REQUIREMENTS OF THE AMBULANCE.....</b>	<b>11</b>
<b>4. AMBULANCE OWNER'S MANUAL .....</b>	<b>13</b>
<b>5. MATERIALS.....</b>	<b>13</b>
5.1 General .....	13
5.2 Insulation .....	14
5.3 Fastenings .....	14
5.4 Plywood .....	14
5.5 Interior Finishes .....	14
<b>6. EXTERIOR IDENTIFICATION .....</b>	<b>15</b>
<b>7. CONSTRUCTION AND DESIGN DETAILS.....</b>	<b>15</b>
7.1 Safety by Design.....	15
7.2 General Construction Methods .....	16
7.3 Cab Headliner.....	16
7.4 Patient Compartment Flooring.....	17
7.5 Bulkhead Partition .....	17
7.6 Patient Compartment Reinforcement Bar.....	18
7.7 Patient Compartment Side Door Step .....	18
7.8 Rear Step Bumper.....	19
7.9 Curb Clearance.....	19
<b>8. HEATING, VENTILATION AND AIR CONDITIONING .....</b>	<b>20</b>
<b>9. LOW VOLTAGE (12V DC) CONVERSION ELECTRICAL SYSTEM .....</b>	<b>21</b>

9.1 General ..... 21

9.2 Electrical Load Isolation ..... 21

9.3 Conversion Battery ..... 22

9.4 Uninterruptible Conversion Power Circuits ..... 22

9.5 Fuses and Circuit Breakers ..... 22

9.6 Driver's Switch Panel ..... 22

9.7 Patient Compartment Switch Panel..... 23

9.8 Door Activated Switches ..... 23

9.9 Door Ajar Light ..... 23

9.10 Two-Way Radio Power Supply ..... 23

9.11 Patient Compartment Lighting ..... 24

9.12 Incubator Receptacles ..... 25

9.13 Cabinetry Lighting ..... 25

9.14 Relays ..... 25

9.15 Electrical Load Rating ..... 26

9.16 Wiring ..... 26

9.17 Backup Warning Alarm ..... 26

**10. EMERGENCY WARNING SYSTEM ..... 27**

10.1 Design Parameters ..... 27

10.2 Forward Roof Warning Lights ..... 29

10.3 Side and Rear Roof Level Warning Lights ..... 29

10.4 Scene Lights ..... 30

10.5 Grille Lights ..... 31

10.6 Intersection Lights ..... 31

10.7 Siren - Public Address System ..... 31

**11. 2-WAY RADIO INSTALLATIONS ..... 32**

11.1 General ..... 32

11.2 Radio Equipment Mounting..... 33

11.3 Antennae Access ..... 34

11.4 Antenna Ground Plane ..... 34

11.5 Cable Routing ..... 35

11.6 Installation of Radio Equipment ..... 35

<b>12. OXYGEN SYSTEM</b> .....	36
12.1 General .....	36
12.2 Oxygen Outlet(s) .....	36
12.3 Oxygen Cylinder Storage.....	36
<b>13. SUCTION ASPIRATION SYSTEM</b> .....	37
<b>14. ACCOMMODATION AND STORAGE</b> .....	37
14.1 General .....	37
14.2 Main Cot Mounting.....	38
14.3 Action Area(s) .....	38
14.4 Auxiliary Seating (Dual Main Cot Ambulance) .....	38
14.5 Storage Requirements and Design .....	39
14.6 Waste Receptacles.....	39
14.7 Incubator Rear Tie-down .....	40
<b>15. SAFETY EQUIPMENT</b> .....	40
15.1 Bolsters .....	40
15.2 Grab Handles/Grab Rails.....	40
15.3 Exterior door safety indicator .....	41
15.4 Fire Extinguishers.....	41
15.5 Passenger Restraint .....	42
<b>16. INTERIOR SIGNS AND LABELS</b> .....	43
<b>17. MODULAR AMBULANCE BODY- TYPE 1 AND TYPE 3</b> .....	44
17.1 General .....	44
17.2 Body Mounting .....	44
17.3 Doors.....	45
17.4 Windows .....	45
17.5 Door Latches .....	45
<b>18. AMBULANCE CHASSIS SPECIFICATION</b> .....	46
18.1 Payload Allowance.....	46
<b>19. CERTIFICATION OF AN AMBULANCE MODEL</b> .....	46
19.1 General .....	46
19.2 Certificates and Reports .....	49
19.3 Certificate Distribution .....	52

19.4	Non-Compliant Vehicles .....	52
19.5	Continued Compliance.....	53
19.6	Compliance Review Program .....	53
19.7	Revocation and Suspension of an Ambulance Certification .....	54
19.8	Fees.....	55
<b>20.</b>	<b>AMBULANCE PERFORMANCE STANDARDS .....</b>	<b>56</b>
20.1	Main Cot Retention.....	56
20.2	Static Load Test for Ambulance Body Structures.....	58
20.3	HVAC Performance Tests .....	62
20.4	Pressure Vessel Retention .....	66
20.5	Interior Sound Level Test .....	68
20.6	Vehicle Weight Distribution.....	71
20.7	Centre of Gravity Location:.....	74
20.8	12 Volt dc Electrical System Performance .....	75
20.9	<i>Intentionally Deleted</i> .....	78
20.10	Antennae Ground Plane Test.....	78
20.11	Interior Lighting Test.....	79
20.12	Oxygen System Pressure Test .....	80
20.13	<i>Intentionally Deleted</i> .....	81
20.14	<i>Intentionally Deleted</i> .....	81
20.15	Body Door Components Test.....	81
20.16	Emergency Lighting Requirements .....	82
20.17	Carbon Monoxide Levels .....	84
20.18	Load Test for Grab Rail/Handles .....	86
20.19	Siren/Public Address System Sound Levels .....	88
20.20	Incubator Restraint Load .....	90
20.21	Passenger and Patient Safety Restraints Load.....	91
20.22	10 G restraint test.....	92
20.23	Occupant Restraint Load Test.....	93
20.24	Occupant Head Protection Zone.....	94
	<b>Annex A – Emergency Response Vehicle Requirements.....</b>	<b>97</b>
	<b>Annex B - REMOUNTED AMBULANCE TRANSFER OF PATIENT COMPARTMENT MODULE.....</b>	<b>116</b>

**Annex C – New Ambulance Compliance Checklist ..... 121**  
**ANNEX D - REMOUNTED AMBULANCES COMPLIANCE CHECKLIST ..... 125**  
**ANNEX E - ERV COMPLIANCE CHECKLIST ..... 130**

# ONTARIO PROVINCIAL LAND AMBULANCE AND EMERGENCY RESPONSE VEHICLE STANDARD

## 1. SCOPE OF THE STANDARD

- 1.1 This Ontario Provincial Land Ambulance and Emergency Vehicle Standard (hereinafter the “Standard”) describes the minimum mandatory requirements for land ambulances for use by an Operator of a land ambulance service.
- 1.2 Annex A of this Standard describes the minimum mandatory requirements for Emergency Response Vehicles intended for use in ambulance services in the Province of Ontario.
- 1.3 Annex B of this Standard describes the minimum mandatory requirements for the transfer of a Patient Compartment Module to another chassis intended for use in ambulance services in the Province of Ontario.
- 1.4 Annex C of this Standard is the Compliance Checklist for a new ambulance.
- 1.5 Annex D of this Standard is the Compliance Checklist for a remounted ambulance.
- 1.6 Annex E of this Standard is the Compliance Checklist for a new ERV.
- 1.7 Every Operator of a land ambulance service shall be responsible for fully complying, or ensuring full compliance, with every provision of this Standard.

## 2. DEFINITIONS

- 2.1 In this Standard "ambulance" has the same meaning as in the Ambulance Act; Ambulances under this Standard shall include the following category of vehicles:
- (1) "Type 1 Ambulance" means a conventional truck cab and chassis with a remountable modular body that contains the patient compartment;
  - (2) "Type 2 Ambulance" means a standard van with integral cab and body, the patient compartment contained within the body, and a raised roof over the patient compartment;

(3) "Type 3 Ambulance" means a cutaway van cab and chassis with a remountable modular body that contains the patient compartment; and

(4) "Special Purpose Ambulance" means an ambulance that is built and equipped for a specific non-standard application, and for which the design, construction, accommodation, safety, and certification requirements have been approved by the Director;

2.2 "CCHS" means the Canadian Community Health Survey;

2.3 "CMVSS" means the Canadian Motor Vehicles Safety Standards;

2.4 "Contractor" means the entity or person undertaking the work of a new or remounted ambulance or ERV conversion.;

2.5 "CSA" means the Canadian Standards Association;

2.6 "C-UL" means the Underwriters Laboratories of Canada;

2.7 "Director" means the Director, Emergency Health Regulatory and Accountability Branch;

2.8 "Emergency Response Vehicle" (ERV) has the same meaning as in Ontario Regulation 257/00;

2.9 "EV" means electric vehicle;

2.10 "Heavy-duty" means in excess of the usual quality or capacity that is normally supplied as standard production material and represents the most durable item that is commercially available;

2.11 "HTA" means the Ontario *Highway Traffic Act*;

2.12 "Main Cot" means a cot of a wheeled design, adjustable to multi-levels and fully contoured for head and/or lower limb elevation as per the PES;

2.13 "Main Cot Retention System" means a mechanical system which provides means for securing a Main Cot to the floor and/or sidewall of an ambulance;

- 2.14 "OH&S" means the Ontario *Occupational Health and Safety Act* and its regulation for Industrial Establishments;
- 2.15 "Operator" means an operator of a land ambulance service, as certified by the Ministry of Health and Long-Term Care pursuant to the *Ambulance Act*;
- 2.16 "Original Equipment Manufacturer" (OEM) means the manufacturer of the vehicle chassis used in the ambulance or ERV conversion;
- 2.17 "PES" means the version of the 'Provincial Equipment Standards for Ontario Ambulance Services' which is in effect at the time of conversion of the ambulance or ERV;
- 2.18 "Purchaser" means the person, entity, company, organization, or body purchasing the new or remounted ambulance or ERV;
- 2.19 "Remount" means an ambulance assembled using an existing patient compartment module on another chassis;
- 2.20 "SAE" means SAE International;
- 2.21 "Wig Wags" means the operation of the alternating white grille lights;

### **3. GENERAL REQUIREMENTS OF THE AMBULANCE**

- 3.1 Each ambulance shall comply with the following documents. In the event of a conflict or inconsistency in any of the provisions found in the following documents, the conflict or inconsistency shall be resolved in favor of the following priority of the documents:
- (1) the Canadian Motor Vehicle Safety Standards (CMVSS);
  - (2) Applicable sections of the HTA;
  - (3) This Standard;
  - (4) any criteria established by the OEM for the conversion of chassis to ambulances or emergency vehicles; and

(5) all relevant Standards and Recommended Practices of technical agencies and bodies referred to in this *Standard*.

- 3.2 Each ambulance shall comply with the version of the documents listed in section 3.1 that were in effect at the time that the manufacturing of the ambulance was completed.
- 3.3 Each ambulance shall be constructed with the operating accessories as required herein; furnished with such modifications and attachments as may be necessary to enable the vehicle to function reliably and efficiently in its intended operating environment.
- 3.4 All modifications or additions to the OEM chassis shall be completed using approved OEM practices.
- 3.4.1 All modified equipment shall meet or exceed OEM performance characteristics.
- 3.5 Each ambulance shall be constructed in accordance with the best standards of current industry practice regarding workmanship and quality.
- 3.6 Any attached drawings, annexes and appendices are incorporated into, and form a part of, this *Standard*.
- 3.7 When an ambulance is equipped with 110v electrical power,
- (1) each outlet shall have an indication that power to the outlet(s) is present;
  - (2) The 110v power supply shall be verified to ensure it is clean and free from interference or fluctuations;

- (3) Such installations shall be completed in accordance with relevant Ontario law governing 110v installations in vehicles; and
- (4) All electrical installations shall be inspected and approved by an inspector certified under relevant Ontario law, an approved seal or certificate of approval shall be affixed adjacent to the installation.

#### **4. AMBULANCE OWNER'S MANUAL**

- 4.1 Each ambulance shall be equipped with an ambulance owner's manual that,
- (1) shall contain instructions on the operation, maintenance and repair of the ambulance and all installed equipment; and
  - (2) shall contain any relevant safety precautions for the ambulance or installed equipment.
- 4.2 Each ambulance shall be equipped with a copy of all literature supplied with the chassis by the OEM chassis manufacture, including the OEM owner's manual.

#### **5. MATERIALS**

##### **5.1 General**

- 5.1.1 No materials shall be used in the conversion of the ambulance that could result in an exposure to biological or chemical agents as referred to in the Ontario *Occupational Health and Safety Act* or its regulations and the Canada *Hazardous Products Act* or its regulations.
- 5.1.2 No asbestos or product using or containing asbestos shall be used in the conversion of ambulances.

## 5.2 Insulation

- 5.2.1 All insulation shall be non-toxic, non-settling type, vermin proof, mildew proof, fire retardant and non-hygroscopic.
- 5.2.2 All insulation shall be secured to prevent movement and to prevent retention of moisture leading to corrosion of surrounding materials.

## 5.3 Fastenings

- 5.3.1 All fasteners and other means of attachment used in the construction or modification of the ambulance or ERV shall be designed to provide a minimum restraining force of 10 times the weight of the component, fasteners and/or object being secured.
- 5.3.2 All attachments shall be fastened in a manner that precludes unintentional loosening.
- 5.3.3 All cabinets, benches, partitions, and rails shall be securely attached to metal tapping plates and/or framing welded or glued to the body structure.

## 5.4 Plywood

All plywood shall be industry standard solid core, with no voids for structural elements, and with waterproof glue construction.

## 5.5 Interior Finishes

- 5.5.1 The finish of all interior surfaces, other than OEM, shall be impervious to soap and water, disinfectants, and mildew.
- 5.5.2 All surfaces, edges, corners, and joints that can be exposed to any fluid shall be sealed by a waterproof bonding material.

## **6. EXTERIOR IDENTIFICATION**

- 6.1 Each ambulance shall display reflective signage stating "AMBULANCE" on both sides, the rear, and the hood of the ambulance, in a contrasting color to the background.
- 6.2 For the sides and rear, the "AMBULANCE" legend shall be a minimum of 170 mm high, capitalized, and proportional in width with bold font lettering, and in a contrasting color to the background.
- 6.3 For the hood, the "AMBULANCE" legend shall be;
- (1) a minimum of 120 mm high,
  - (2) capitalized,
  - (3) proportional in width with bold font lettering,
  - (4) in a contrasting color to the background, and.
  - (5) permitted to be a mirror image

## **7. CONSTRUCTION AND DESIGN DETAILS**

### **7.1 Safety by Design**

- 7.1.1 The interior of the patient and driver compartments shall be free of all sharp projections.
- 7.1.2 All hangers or supports for equipment, lighting, controls, and other devices shall be mounted as flush as possible with the surrounding surface.
- 7.1.3 Padding (bolsters) shall be placed at all head areas and on all obstructions that may be dangerous to persons moving about in the ambulance.

- 7.1.4 All exposed edges and corners that are not padded or protected by "T" moulding shall be cut with the largest possible radius or chamfer, at minimum a 3 mm chamfer or a 15 mm radius.
- 7.1.5 The interior of the patient compartment shall be designed and constructed to minimize containment areas for the incubation of viruses.
- 7.1.6 All stepping surfaces (*e.g.*, front cab and patient compartment step wells) shall be covered with heavy-duty ribbed rubber matting or other anti-skid material for skid protection.
- 7.1.7 All securing straps, cargo nets and other restraints shall be capable of restraining at least 10 times the total weight of the equipment or material they are designed to contain.
- 7.1.8 All doors, hatches and covers shall be designed to contain at least 10 times the weight of the items stored loose behind the door, hatch, or cover.
- 7.1.9 All equipment installed in the cab shall be located and mounted in such a way that it shall not interfere with the operation of the driver side and/or passenger side air bag(s) if the vehicle is so equipped.

## 7.2 General Construction Methods

All panels shall be installed in a manner that prevents sagging, deflection, warping or vibration.

## 7.3 Cab Headliner

If a cab headliner other than the OEM supplied headliner is installed, then the resulting headroom clearance shall not be lower than that of the original OEM cab headliner.

## 7.4 Patient Compartment Flooring

- 7.4.1 The floor of the patient compartment shall be at the lowest level permitted by the chassis or body that does not exceed any limits expressed elsewhere in this Standard.
- 7.4.2 All floor areas shall withstand a distributed load of at least 735 kg/sq. m.
- 7.4.2.1 All floors shall be reinforced to eliminate "stress wrinkling".
- 7.4.3 The floor covering shall,
- (1) be fireproof, no wax type, mark resistant and scuff-proof safety flooring;
  - (2) provide a static friction coefficient equal to or greater than 0.8 under dry conditions; and
  - (3) be warranted by the flooring manufacturer to maintain that factor for at least seven (7) years of use in an ambulance.
- 7.4.4 All floor level mouldings, edging and trim shall be sealed to prevent fluids from seeping under cabinets, walls, etc.

## 7.5 Bulkhead Partition

- 7.5.1 A full height and width bulkhead partition shall,
- (1) be placed between the driver and patient compartments;
  - (2) be located behind the driver and passenger seats; and
  - (3) be secured by being welded/fastened or bolted to tapping plates.
- 7.5.2 The bulkhead shall,
- (1) contain a communication window; and
  - (2) be positioned such that the driver may view the patient compartment by means of the interior rear-view mirror.

7.5.2.1 Ambulances may be exempt from 7.5.2 (2) when an alternate method is installed and available to the driver that maintains a clear view of the patient compartment.

7.5.3 In the construction of the bulkhead, the horizontal seat movement of both the driver and passenger seats shall not be reduced from that provided by the OEM.

7.5.4 For a Type 1 ambulance, the communicating window shall be in the front wall of the ambulance body and accessible to the cab.

## 7.6 Patient Compartment Reinforcement Bar

In Type 2 ambulances, a mild steel reinforcing bar of minimum 100 mm width and 5 mm thickness, or the equivalent, shall,

- (1) run around the total perimeter of the patient compartment, including the doors; and
- (2) be welded/fastened to body ribs, bulkhead reinforcement, door posts, and framework of doors.

## 7.7 Patient Compartment Side Door Step

7.7.1 The side entrance to the patient compartment shall,

- (1) provide ease of access for an ambulatory patient, and
- (2) include stepping surfaces that are minimum 200 mm wide (from edge to riser) and no more than 560 mm above the ground.

7.7.2 Where a permanently fixed exterior step has been installed, it shall be capable of supporting a test weight of at least 225 kg.

7.7.3 For Type 2 ambulances, when allowed by OEM practices, the present patient compartment side entrance step-well shall,

- (1) be widened as necessary to comply, or
- (2) be replaced by a permanently fixed exterior step (running board) capable of supporting a test weight of at least 225 kg.

## 7.8 Rear Step Bumper

7.8.1 Each ambulance shall be equipped with a step bumper at the rear capable of supporting a test weight of at least 225 kg.

7.8.2 The safety grating step shall run the length of the rear door opening, be 240 mm wide and hinge or pivot to permit ambulance attendants to move closer for loading and unloading of cot.

7.8.3 The rear step bumper shall,

- (1) be positioned so that the stepping surface is approximately mid-way between the ground and the finished floor of the ambulance; and
- (2) meet the angle of departure as measured in accordance with section 7.9 of this Standard.

7.8.4 Where a power lift is installed to lift cots into the ambulance, the rear step shall be exempt from the hinge or pivoting requirements of section 7.8.2 of this *Standard*.

## 7.9 Curb Clearance

With the exception of the OEM's furnished and installed components, the ambulance shall meet or exceed the following clearances as measured in accordance with SAE Standard J1100, as follows:

- (1) Approach angle 20°
- (2) Ramp breakover 10°
- (3) Departure angle 10°

## **8. HEATING, VENTILATION AND AIR CONDITIONING**

- 8.1 The heating ventilation and air conditioning (“HVAC”) system shall maintain a comfortable temperature level in the patient compartment.
- 8.2 The HVAC system shall achieve all criteria and performance testing standards as detailed in Section 20 of this *Standard*.
- 8.3 The HVAC system shall be designed to operate using recirculated and/or ambient air.
- 8.4 The HVAC system shall provide a positive pressure within the patient compartment.
- 8.5 The HVAC system provided in the patient compartment shall be installed in a manner that allows for the independent control of the environment in the patient compartment from that of the driver compartment.
- 8.6 If modifications or additions are made to the OEM heater system, then the Contractor shall certify that the windshield defrosting, and defogging system continue to comply with CMVSS #103.
- 8.7 The motors used to exhaust air for the air exchange shall comply with C-UL requirements for spark protection (marine).

- 8.8 A thermostat system shall automatically control the heating and cooling functions so that the temperature in the patient compartment is constant within +/- 2°C.
- 8.9 Where supplied as part of the OEM chassis, the connection points provided by the auxiliary HVAC - connector package shall be used.
- 8.10 In chassis that do not provide an OEM connection point for the heater lines, heavy-duty unions shall be used where the heater hoses connect.
- 8.11 The total air conditioning system shall be connected and charged in accordance with the OEM manufacturer's specifications regarding gas, lubricant, and pressure.

## **9. LOW VOLTAGE (12V DC) CONVERSION ELECTRICAL SYSTEM**

### **9.1 General**

- 9.1.1 The battery(s) that is/are used to operate OEM vehicle functions shall be protected from all other electrical demands.
- 9.1.2 The Contractor shall test each ambulance prior to delivery and provide the Purchaser with certification of compliance with the performance criteria in Section 20 of this *Standard*.

### **9.2 Electrical Load Isolation**

OEM chassis battery(s) (high voltage battery in the case of EV) shall be protected from all Ambulance conversion electrical system loads.

### 9.3 Conversion Battery

9.3.1 The ambulance conversion electrical system shall include a dedicated battery(s) (e.g., the conversion battery(s)) electrically separated from the OEM battery(s).

9.3.2 The conversion battery(s) shall be;

- (1) Located in a compartment sealed off from occupant compartments.
- (2) In the case of vented batteries this compartment shall be ventilated

### 9.4 Uninterruptible Conversion Power Circuits

The following circuits shall be powered at all times: Incubator Receptacles, Two-Way Radio Power Supply, the Emergency Battery Boost System (if so equipped), and a light in the patient's compartment.

### 9.5 Fuses and Circuit Breakers

All circuits shall be protected by properly sized fuses or circuit breakers.

### 9.6 Driver's Switch Panel

9.6.1 Switches to control the emergency warning lights, siren, scene lights and other ambulance functions shall be mounted in a switch panel located at the driver's console.

9.6.2 Design and location of console and switch placement shall favor the driver as primary user but allow access to control functions from the passenger seat.

## 9.7 Patient Compartment Switch Panel

Switches to control the patient compartment lights, heating, air conditioning, and other patient compartment functions shall be mounted on a switch panel at the attendant's control console at the action area(s).

## 9.8 Door Activated Switches

9.8.1 Patient compartment side entrance door(s) shall be fitted with switch(es) which shall operate interior patient compartment lights for general illumination when the door(s) is/are open.

9.8.2 Patient compartment rear entrance door(s) shall be fitted with switches that operate,

- (1) interior patient compartment lights for general illumination; and
- (2) the rear scene lights for loading lights when the door(s) is open.

## 9.9 Door Ajar Light

A flashing red warning light shall be installed on the driver console to indicate when any of the patient compartment or the exterior storage doors is ajar.

## 9.10 Two-Way Radio Power Supply

9.10.1 A terminal block shall be installed in the area provided for the mounting of radio equipment to accommodate the two-way radio power connections

9.10.2 Two terminals shall,

- (1) be included on the Radio Terminal Block; and
- (2) be labelled, one as POSITIVE and one as GROUND.

9.10.3 The positive wire shall,

- (1) be #4-gauge wire
- (2) be connected from the POSITIVE terminal of the block;
- (3) be connected in series with a 40-amp breaker (isolated from all other breakers);  
and
- (4) be connected to the positive post of the conversion battery.

9.10.4 The negative wire shall,

- (1) be #4-gauge wire
- (2) be connected from the GROUND terminal block
- (3) be connected to the metal frame of the chassis, and
- (4) be separate from all other grounds connections on frame.

9.10.5 An insulated cover or terminal protectors shall be installed on the terminal block to prevent accidental contact with the terminals.

## 9.11 Patient Compartment Lighting

The intensity of the illumination in the patient compartment shall comply with the performance criteria in Section 20 of this *Standard*.

## 9.12 Incubator Receptacles

- 9.12.1 Two (2) 12-volt polarized outlets shall,
- (1) be installed in each ambulance; and
  - (2) be powered at all times and protected to 20 amps
- 9.12.1.1 One outlet shall be located near the head end of the primary cot, but not in the action wall.
- 9.12.2 All outlets shall be Cinch Jones Series 2400 (6 contacts) or proven equivalent.
- 9.12.3 All connections shall be soldered to terminals.
- 9.12.3.1 Terminal #11 to negative (ground).
- 9.12.3.2 Terminal #12 to positive.
- 9.12.4 All terminals shall be covered to protect any metal contact from causing short circuits.

## 9.13 Cabinetry Lighting

- 9.13.1 All exterior compartments shall,
- (1) be provided with lighting; and
  - (2) have two (2) function door switches to activate lights.

## 9.14 Relays

Any device subject to a load of 25 amps or greater shall be remotely switched by relays or proven equivalent device.

### 9.15 Electrical Load Rating

All wiring, electrical devices, switches, outlets, etc., except circuit breakers and fuses, shall be rated to carry at least 125 percent of the maximum ampere load for which the circuit is protected.

### 9.16 Wiring

9.16.1 All wiring shall,

- (1) be copper; and
- (2) be SAE J1128 compliant.

9.16.2 No wiring unless protected within a solid channel made of corrosion resistant material shall pass,

- (1) across the floor of the driver compartment;
- (2) under the floor mats; or
- (3) across metal trim strips;

9.16.3 No wiring shall pass or terminate within 200 mm of the oxygen connectors or fittings

### 9.17 Backup Warning Alarm

9.17.1 A heavy-duty reverse warning signal shall,

- (1) be installed in each ambulance; and
- (2) operate when the gear selector is in "REVERSE".

9.17.2 Where a disable switch is installed for silent backing, the disable switch shall be programmed to reset automatically prior to the lapse of 60 seconds from the time the switch is disabled.

## **10. EMERGENCY WARNING SYSTEM**

### **10.1 Design Parameters**

10.1.1 The emergency lighting system shall utilize flashing lights.

10.1.2 The emergency lighting system design shall be implemented and used in the following manner:

- (1) white (clear) or blue light will be used to gain the viewer's attention;
- (2) red light will convey the "emergency" message;
- (3) amber light will convey the "caution" message;
- (4) no colors other than red, white, blue, and amber shall be used;
- (5) all flashing lights of the same light type (e.g., incandescent, halogen strobe or Neobe®) and color shall flash simultaneously, and then alternate to the other color along the same side.
- (6) amber light(s) shall not flash at the same time as any other emergency lights facing in the same direction.

10.1.3 The emergency lighting system shall be comprised of components and devices that comply with requirements of SAE J576, J578, J591, J595, J1318 and J1889, as applicable to the ambulance.

10.1.4 Lighting that is not required to meet the emergency lighting system design requirements in section 10.1.2 are,

- (1) Wig Wags;
- (2) traffic directional devices;

- (3) red or amber stop turn signaling devices required under the HTA; and
- (4) inside exterior door warning lights.

- 10.1.4.1 All lighting referred to in section 10.1.4 shall be capable of independently switching from emergency lights.
- 10.1.5 The primary emergency lighting system shall meet all criteria and performance testing standards as detailed in Section 20 of this Standard.
- 10.5.1.1 The primary emergency lights required to meet the minimum output shall remain visible when doors and compartments are in use.
- 10.5.1.2 The primary emergency lighting system shall,
- (1) be wired to operate independently of the other warning lights; and
  - (2) be controlled by a separate switch on the driver's console.
- 10.1.5.3 The primary emergency lighting flash pattern shall include;
- (1) forward roof warning lights;
  - (2) side roof level warning lights;
  - (3) rear roof level warning lights;
  - (4) grille lights; and
  - (5) intersection lights.

## 10.2 Forward Roof Warning Lights

- 10.2.1 Each ambulance shall have an array of red and either white or blue flashing lights installed on the forward vertical plane of the raised roof or the modular ambulance body.
- 10.2.2 This array shall include a minimum of two (2) red lights and one (1) white or blue light.
- 10.2.3 The red light(s) shall be in the extreme upper outer corner(s).

## 10.3 Side and Rear Roof Level Warning Lights

- 10.3.1 Each ambulance shall have an array of red and either white or blue flashing lights visible on each side.
- (1) The red light(s) shall be in the extreme upper outer corner(s).
  - (2) This array shall include a minimum of two (2) red lights and one (1) white or blue light.
- 10.3.2 Each ambulance shall have an array of red and either white or blue flashing lights visible on the rear.
- (1) The red light(s) shall be in the extreme upper outer corner(s).
  - (2) This array shall include a minimum of two (2) red lights and one (1) white or blue light.

## 10.4 Scene Lights

- 10.4.1 Five (5) white (i.e., clear) scene lights shall be installed on the vertical plane of the outer roof skin.
- 10.4.1.1 Of these five (5) white (i.e., clear) scene lights,
- (1) one spotlight shall be located forward on each side;
  - (2) one floodlight shall be located to the rear on each side; and
  - (3) one floodlight shall be located on the rear.
- 10.4.1.2 The floodlights shall be angled downward 12 to 15 degrees by means of mounting or lens and installed with minimum protrusion beyond the outer skin of the body.
- 10.4.2 Switches at the driver control console shall control the left, right and rear facing scene lights.
- 10.4.3 At least one adjacent floodlight shall illuminate automatically when the rear doors of the patient compartment are opened.
- 10.4.4 The rear facing scene light(s) shall also operate automatically when the vehicle transmission is placed in reverse.
- 10.4.5 If scene lights are used to fulfil the requirement for white lights in the side and rear roof level warning lights, they shall be wired to flash as part of the primary emergency warning system.

## 10.5 Grille Lights

10.5.1 Each ambulance shall have grille lights installed on the vertical plane of the grille such that:

- (1) the location is in compliance with OEM considerations regarding air flow through the grille; and
- (2) the lights are visible in the rear-view mirror(s) of a passenger car preceding the ambulance.

10.5.1.2 The grille lights shall contain:

- (1) Two (2) red lights; and
- (2) Two (2) white lights (Wig Wags)

10.5.1.3 Wig Wags shall;

- (1) flash in an alternating or random sequence. (which may be the high beam of the OEM headlights when permitted by the OEM)
- (2) be wired to operate independently of the other warning lights
- (3) be controlled by a separate switch on the driver's console
- (4) when an alternating pattern is selected of the same type of light as the red emergency grille lights, the flash rate shall be faster

## 10.6 Intersection Lights

Each ambulance shall have a red light and either a white or blue intersection light(s) installed at each of the front lower corners of the vehicle.

## 10.7 Siren - Public Address System

10.7.1 Each ambulance shall have a combination siren and public address system.

- 10.7.1.1 The combination siren and public address system shall,
- (1) be capable of producing high/low horn tones and other warning sounds;
  - (2) contain a microphone and two speakers; and
  - (3) achieve criteria as detailed in section 20 of this Standard.
- 10.7.2 The siren shall:
- (1) be capable of amplifying the two-way radio audio;
  - (2) be independent of the radio system;
  - (3) have remote control capability; and
  - (4) be able to be activated by the vehicle horn ring when the siren/horn switch is on.

## **11. 2-WAY RADIO INSTALLATIONS**

### **11.1 General**

- 11.1.1 Each ambulance design shall provide for the installation of radio equipment.
- 11.1.2 The term "radio equipment" means all peripheral equipment associated with the radio, including:
- (1) mobile radio units that consist of the mobile radio transceiver and the mobile radio repeater package;
  - (2) front control heads, microphones, and speakers;
  - (3) all associated antennas
  - (4) cables between the control head, speaker, mobile radio unit, battery, and antenna;

- (5) rear control head, handset, and speakers; and
- (6) two portable radios.

## 11.2 Radio Equipment Mounting

11.2.1 Each ambulance shall have a compartment for mounting radio equipment which:

- (1) provides adequate access for installation or removal and periodic maintenance;
- (2) provides protection from physical damage; and
- (3) is ventilated.

11.2.2 A mounting position shall be provided for the radio control head and microphone clip in the cab that allows equal access for either the driver or passenger and does not impede the OEM line of sight out of the vehicle.

11.2.3 A mounting position shall be provided for two (2) remote speakers to be mounted in the following locations:

- (1) In the cab between the driver and passenger; and
- (2) near the rear facing attendant seat.

11.2.4 The mounting of radio equipment shall not:

- (1) interfere with other control functions;
- (2) block vents;
- (3) block the line of sight for gauges or instruments;
- (4) interfere with air bag type passenger restraint systems; or
- (5) encroach into the paramedic seating area.

### 11.3 Antennae Access

11.3.1 Access shall be provided to enable the installation and maintenance of antennae and antenna cables without having to remove the headliners or cabinets.

11.3.2 Openings to pass antenna cables through walls etc. shall:

- (1) be at least 25 mm in diameter.
- (2) protected to prevent wear or damage to cables

### 11.4 Antenna Ground Plane

11.4.1 Each ambulance equipped with a non-metallic roof shall have an antenna ground plane that is at least 1 square meter and shall be moulded into the roof.

11.4.2 The ground plane shall,

- (1) be grounded to the vehicle frame; and
- (2) meet ground plane test as detailed in section 20 of this Standard.

11.4.3 The total thickness of the roof and ground plane shall not exceed 10 mm for a 75 mm diameter circle at each mount point.

11.4.4 With respect to MOH trunked radios,

- (1) There shall be a minimum separation of 915mm at each antenna mount point;  
and;

- (2) The lower surface of the ground plane shall be exposed to enable contact with the antenna mount.

## 11.5 Cable Routing

11.5.1 Cables between the radio compartment and the radio control head, the remote speakers and the remote handset shall be protected from wear and damage by means such as:

- (1) passages between sections of cabinetry;
- (2) fixed conduits with a minimum inside dimension of 75x50 mm; or
- (3) removable channels with a minimum inside dimension of 60x35 mm.

## 11.6 Installation of Radio Equipment

11.6.1 All fasteners and other means of attachment used to install radio equipment in ambulances shall provide a minimum restraining force of at least 10 times the weight of the component or object being secured.

11.6.2 All attachments shall be fastened in a manner that prevents unintentional loosening.

11.6.3 No mounting of radio equipment shall,

- (1) interfere with other control functions;
- (2) block vents or instruments;
- (3) interfere with air bag passenger restraint systems; or
- (4) encroach into the paramedic seating area, and;
- (5) does not impede the OEM line of sight out of the vehicle

## 12. OXYGEN SYSTEM

### 12.1 General

- 12.1.1 Each ambulance shall have a hospital type oxygen system that,
- (1) is capable of storing and supplying medical oxygen as specified by the PES; and
  - (2) complies with all requirements as detailed in section 20 of this Standard.
- 12.1.2 All threaded fittings shall be gas specific (CSA) and cleaned for oxygen service.
- 12.1.3 All devices shall be color coded to indicate oxygen.
- 12.1.4 All apparatus shall be permanently identified with the manufacturer's name, calibrated conditions and specific markings including warning information.
- 12.1.5 All oxygen lines running between the storage tank regulator and the wall outlets shall be low pressure hose assemblies.

### 12.2 Oxygen Outlet(s)

- 12.2.1 All oxygen outlets shall;
- (1) be compatible with oxygen delivery equipment specified by the PES; and
  - (2) be located so as not to pose a hazard to occupants.

### 12.3 Oxygen Cylinder Storage

All oxygen cylinder storage devices shall be designed and mounted so as to comply with the criteria for oxygen tank retention as detailed in section 20 of this *Standard*.

### **13. SUCTION ASPIRATION SYSTEM**

- 13.1 Each ambulance shall have a complete electrically powered suction aspiration system installed as specified by the PES.
- 13.2 All suction outlets and associated equipment shall be located so that they do not pose a hazard to the patient on the cot, whether the head of the cot is reclined or in any elevated position, or to the attendant.

### **14. ACCOMMODATION AND STORAGE**

#### **14.1 General**

- 14.1.1 As a minimum, each ambulance shall be designed to accommodate:
- (1) one patient on a Main Cot, incubator, or other mobile patient transporter;
  - (2) seating for one paramedic and one other passenger in patient compartment in addition to the patient; and
  - (3) the driver and one other passenger in the cab.
- 14.1.2 Where the Director has approved different design and accommodation requirements for special purpose ambulances from those set out in section 14.1.1, each special purpose ambulance shall comply with the approved requirements

## 14.2 Main Cot Mounting

- 14.2.1 Each ambulance shall conduct testing on Main Cot retention systems in accordance with the performance criteria as detailed in section 20 of this *Standard*.
- 14.2.2 All Main Cots shall be positioned so that there is a minimum of 150 mm of clearance between the rearmost part of the cot and the nearest obstruction.

## 14.3 Action Area(s)

- 14.3.1 Each ambulance shall provide an action area(s) for the attendant seated in the primary attendant seat.
- 14.3.2 All action areas shall contain:
- (1) the main oxygen outlet and controls;
  - (2) the suction outlet and controls;
  - (3) the attendant control console (patient compartment switch panel);
  - (4) a thermostat for HVAC system(s);
  - (5) a reading light; and
  - (6) mounting space for the two-way radio handset and speaker.
- 14.3.3 All switches on the action area(s) shall be recessed or otherwise protected from accidental operation.

## 14.4 Auxiliary Seating (Dual Main Cot Ambulance)

- 14.4.1 Each dual Main Cot ambulance shall have a rear facing seat securely mounted at the front right of the patient compartment to enable the occupant to observe a patient on the second cot.

- 14.4.2 The auxiliary seat shall be equipped with a permanently mounted seat, back, headrest cushions and a seat belt that meets the criteria of section 20 of this *Standard*

#### 14.5 Storage Requirements and Design

- 14.5.1 Each ambulance shall be designed with adequate storage for all minimum mandatory equipment as specified by the PES.
- 14.5.2 All storage cabinets shall be fastened in a way that allows them to be easily opened, while ensuring they do not come open in transit or as a result of a vehicle collision.
- 14.5.3 All doors, hatches and covers shall be designed to contain at least 10 times the total weight of the items stored loose behind the door, hatch, or cover.
- 14.5.4 All open shelves or compartments shall be provided with easily removable belts or cargo nets designed to contain at least 10 times the total weight of the items stored loose on the shelf or in the compartment.
- 14.5.5 All glazing in cabinet doors shall bear a permanent identifying mark certifying compliance with current Transport Canada Regulations for motor vehicle glazing.

#### 14.6 Waste Receptacles

Each ambulance shall have individual receptacles provided for trash, hazardous waste, and sharps.

## 14.7 Incubator Rear Tie-down

14.7.1 A minimum of two (2) fixtures to secure the rear tie-downs for incubators are to be mounted at the rear door threshold. The fixtures shall be installed:

- (1) in a manner that minimizes the potential tripping hazard;
- (2) Not to interfere with the travel of the main cot; and
- (3) One (1) be positioned along the longitudinal centerline of the stretcher

## 15. SAFETY EQUIPMENT

### 15.1 Bolsters

15.1.1 Bolsters (padded cushions) shall be installed at all openings, projections and obstructions inside the ambulance that may cause danger to persons moving, seated, or entering and leaving the ambulance.

15.1.2 At a minimum, bolsters shall be installed:

- (1) across the full width of the interior top sill of each door opening in the patient compartment; and
- (2) adjacent to each seating position.

### 15.2 Grab Handles/Grab Rails

15.2.1 Each ambulance shall have grab handles and grab rails installed to assist persons who are moving or seated inside the ambulance or entering and exiting the ambulance.

15.2.2 All grab rails and handles shall be installed in compliance with the criteria set out in section 20 of this *Standard*.

### 15.3 Exterior door safety indicator

Each ambulance shall have one or more of the following installed on the outer edge of all exterior doors to enhance visibility of these doors when open:

- (1) Reflective safety stripes;
- (2) Reflective lenses; and
- (3) Flashing warning lights.

### 15.4 Fire Extinguishers

15.4.1 Each ambulance shall have two (2) fire extinguishers which meet the following requirements:

- (1) 5lb;
- (2) C-UL approved;
- (3) rating 3-A, 10 BC; and
- (4) rechargeable type with pressure gauge and service inspection tag.

15.4.1.1 The fire extinguishers shall be installed in the following locations:

- (1) One in the cab; and
- (2) One in the patient compartment.

15.4.2 All fire extinguishers shall be secured by a quick release bracket or in a container that,

- (1) does not require adjustment each time the fire extinguisher is secured; and
- (2) complies with the retention criteria in section 20 of this Standard.

## 15.5 Passenger Restraint

- 15.5.1 All seating positions in each ambulance shall have seat belts that comply with CMVSS standards.
- 15.5.1.1 Where there is no regulation under CMVSS, the installation, materials and design of the seat belts shall meet the spirit of CMVSS regulations for passenger restraint.
- 15.5.1.2 All seat belt installations shall comply with criteria in section 20 of this Standard.
- 15.5.2 All seat belts shall provide pelvic restraint designed to remain on the pelvis of the occupant.
- 15.5.3 All side facing seats shall have a net, shoulder belt or a vertical bolster located at the forward edge of the seat area that,
- (1) meets the requirements set out in section 20 of this Standard; and
  - (2) restrains the occupant(s) along the side of their body and head to prevent extensive flexing of the spine or neck.
  - (3) for multiple occupant bench seat, 15.5.3 (1 and 2) only applies to the forward most seating position

## 16. INTERIOR SIGNS AND LABELS

Each ambulance shall have the following labels;

- (1) instructions beside each egress door of the patient compartment to indicate how to open door(s);
- (2) a label on each pressure vessel holder indicating the type, size of tank(s) and maximum weight of tank(s) it is intended to restrain;
- (3) Radio equipment mounting location(s) as defined in section 11.1.2 (1) and (2);
- (4) labels on all accessory receptacles and other electrical outlets indicating intended use (e.g., 12V, 20amp or 110VAC 15amp);
- (5) a decal in the patient compartment view of the attendant(s) stating 'all storage area, securing strap, bracket and/or cargo net has a maximum rating of 14kg/30lbs unless otherwise labelled;
- (6) a label on each storage area, securing strap, bracket and/or cargo net rated to secure above 14kg/30lbs;
- (7) labels on all switches and temperature controls;
- (8) a label on each waste receptacle indicating their intended use;
- (9) a decal in clear view of the driver indicating the overall height of the vehicle both in meters and feet, including an allowance of 500 mm (20 inches) for the roof mounted antenna; and
- (10) Weight decal displayed in clear view of the driver indicating at minimum;
  - (i) The payload in kilograms and pounds
  - (ii) The maximum number of occupants x 90% Male, in accordance with the current Canadian Community Health Survey (CCHS)

- (iii) The equipment weight – if supplied by Operator
- (iv) The Cargo Carrying Capacity (C.C.C) in kilograms and pounds

Sample Decal:

Maximum Payload

= \_\_\_\_\_ kg/ \_\_\_\_\_ lbs.

Equipment

=

\_\_\_\_\_ kg/ \_\_\_\_\_ lbs.

C.C.C. = \_\_\_\_\_ kg/ \_\_\_\_\_ lbs.

Equivalent Maximum Occupants @ 90% male = \_\_\_\_\_ @ 241 lbs. each

**17. MODULAR AMBULANCE BODY- TYPE 1 AND TYPE 3**

**17.1 General**

Each modular ambulance body shall comply with the Ambulance Performance Standards set out in section 20 of this *Standard*.

**17.2 Body Mounting**

17.2.1 Each modular ambulance body shall be mounted to the chassis with high strength fasteners and vibration isolating rubber body mounts designed and installed in accordance with the chassis manufacturer's guidelines.

17.2.2 Modular ambulance bodies shall not be welded to the frame.

### 17.3 Doors

17.3.1 Each ambulance shall have door openings to the patient compartment provided at the rear of the body and on the curbside ahead of the right rear wheel.

17.3.2 Each door shall have,

- (1) hold open devices appropriate for the type and size of door; and
- (2) door stops to prevent damage to body.

17.3.3 The rear door(s) shall provide;

- (1) a minimum opening of 1120 mm wide x 1270 mm high.
- (2) doors with vertical hinges shall open to a minimum door angle of 150 degrees.

17.3.4 The curbside door opening shall provide a minimum opening of 700mm x 1270mm to accommodate the emergency removal of patients.

### 17.4 Windows

Each ambulance shall have fixed windows mounted in the rear doors.

### 17.5 Door Latches

17.5.1 All door latches shall be;

- (1) automotive style;
- (2) Transport Canada approved; and
- (3) equipped with a two (2) stage catch mechanism.

- 17.5.2 All egress doors shall have lock and release handles permitting the doors to be locked or unlocked from inside the patient compartment without using a key.

## **18. AMBULANCE CHASSIS SPECIFICATION**

### **18.1 Payload Allowance**

- 18.1.1 Each ambulance shall have a minimum payload allowance of 770 kg (1700 lbs.) over and above the converted curb weight of the unit as measured per subsection 20.6.3.3.
- 18.1.2 The total weight of the occupants and cargo shall not exceed the payload allowance.

## **19. CERTIFICATION OF AN AMBULANCE MODEL**

### **19.1 General**

- 19.1.1 Prior to being in service, every new and remounted ambulance model of ambulances intended to be used in the Province shall be certified in accordance with this *Standard* by the Director.
- 19.1.2 The process for Ministry certification of an ambulance model may include site visits to the Contractor's production and testing facilities at times when the Director determines that manufacturing or performance standard testing of ambulances intended for use in Ontario is occurring.
- 19.1.3 To facilitate the site visits described in section 19.1.2, the Contractor shall:
- (1) provide the Director with a minimum of 60 calendar days' notice prior to commencing testing of ambulances;

- (2) provide the Director with a copy of the "Ministerial Authorization" for the use of the National Safety Mark issued by Transport Canada relevant to the ambulance model for Canadian Contractors; and
- (3) If the Contractor is International, proof of the vehicles admissibility into Canada shall be required.

19.1.4 The Contractor shall apply for certification of an ambulance model by submitting the following documentation:

- (1) a letter signed by the Contractor stating that the ambulance model as offered for use in the Province of Ontario is in compliance with all provisions of this *Standard*;
- (2) a copy of all test certificates and technical reports required for the Performance Standards set out in section 20 of this Standard;
- (3) a copy of the Owner's Manual required under Section 4;
- (4) a copy of the "Ministerial Authorization" for the use of the National Safety Mark issued by Transport Canada relevant to the ambulance model for Canadian Contractors;
- (5) If the Contractor is International, proof of the vehicles admissibility into Canada shall be required.
- (6) an electrical schematic drawing which clearly explains how the isolation of loads required under section 9 has been accomplished.
- (7) a completed copy of Annex C (New Ambulance) or Annex D (Remounted Ambulance) noting compliance with specified sections of the Standard, signed by an officer of the Contractor, dated and notarized; and
- (8) the test submission, which shall include a model or part numbers of products tested and a pictorial record of the tests.

- 19.1.5 Each ambulance model certification shall be,
- (1) granted solely at the discretion of the Director; and
  - (2) in writing.
- 19.1.6.1 Ambulance model certification and individual test certificates shall remain valid for a maximum of four (4) years.
- 19.1.6.1.1 After the expiry of the four (4) year period, and subject to sub-section the ambulance model shall be recertified.
- 19.1.6.2 The start date for the four (4) year period of ambulance model certification shall be determined based on the date that the oldest test was completed, as submitted under sub-section 19.1.4 (2).
- 19.1.7 In lieu of recertification, a Contractor may make an application to the Director of the Emergency Health Regulatory and Accountability Branch to have the term of an ambulance model certification or of an individual test certificate extended for an additional period of two years from the original test date.
- 19.1.7.1 The application shall,
- (1) be completed prior to the expiry of the original certificate; and
  - (2) include a detailed argument, based on sound engineering principles, explaining why the extension should be granted.

- 19.1.7.2 All extensions shall be,
- (1) granted solely at the discretion of the Director; and
  - (2) in writing.
- 19.1.7.3 A maximum of one extension shall be allowed for any individual certification.
- 19.1.8 Each ambulance certified for use in Ontario under previous versions of this Standard shall be deemed to continue to be certified under the current version until sold, remounted, refurbished, or modified in any fashion which contravenes the version in effect at the time of change.

## 19.2 Certificates and Reports

- 19.2.1 The Contractor shall,
- (1) retain on file the original copy of all valid test certificates required under the Performance Standards set out in section 20; and
  - (2) complete technical reports in support of those certificates.
- 19.2.2 Each individual test certificate shall clearly state:
- (1) the number, title, and date of revision of the Performance Standard;
  - (2) the date and location when the test was performed;
  - (3) the name of the company or organization which completed the test;
  - (4) the name and title of the person who has verified the test results complete with a signature (and proof of license for an engineer);
  - (5) that the test requirements were passed;
  - (6) the chassis type(s) and ambulance type(s) for which the certificate is valid;

- (7) the make, model, year, and Vehicle Identification Number of the tested chassis;
- (8) the make, model, type, and year of the tested ambulance conversion;
- (9) the make, model, and other identifying marks on any components being tested or that make up systems which are being tested;
- (10) the make, model, and other identifying marks on any components being tested or that make up systems which are being tested, including photographs or diagrams that clearly distinguish the components or systems for future reference; and
- (11) an individualized test certificate reference number.

19.2.3 Each technical report held in support of a test certificate shall contain at minimum:

- (1) all information required on the test certificate;
- (2) all data collected in performance of the test including any descriptive or explanatory notes, pictures, and videos;
- (3) a description of the equipment and facilities used to perform the tests; and
- (4) the next calibration due date.

19.2.4 The following tests shall be completed by a Licensed Ontario Professional Engineer and certified as conforming to the following Performance Standards:

- (1) Main Cot Retention;
- (2) Static Load Test for Ambulance Body Structures;
- (3) HVAC Performance Tests;

- (4) Pressure Vessel Retention;
- (5) Interior Sound Level Test;
- (6) Centre of Gravity Location;
- (7) Interior Lighting Test;
- (8) Body Door Components Test;
- (9) Emergency Lighting Requirements;
- (10) Carbon Monoxide Levels;
- (11) Load Test for Grab Rail/Handles;
- (12) Siren/Public Address System Sound Levels;
- (13) Passenger and Patient Safety Restraints Load Tests;
- (14) 10G Restraint Test;
- (15) Occupant Restraint Load Test; and
- (16) Incubator Restraint Load Test.

19.2.5 The following tests shall be completed by the Contractor and certified as conforming to the following Performance Standards:

- (1) Vehicle Weight Distribution;
- (2) 12 Volt dc Electrical System Performance;
- (3) Antenna System Test;
- (4) Oxygen System Pressure Test; and
- (5) Occupant Head Protection Zone.

19.2.6 Certification from the OEM chassis manufacturer and individual equipment manufacturers shall be accepted if they:

- (1) are not part of a system(s);

- (2) are not altered; and
- (3) are in accordance with sub-section 19.2.2 of this Standard.

19.2.7 Testing results of single components produced by the OEM chassis manufacturer and individual equipment manufacturers shall be accepted if:

- (1) the component tested is not incorporated or utilized as part of a larger system or entity;
- (2) the component tested is not altered; and
- (3) the results are in accordance with sub-section 19.2.2 of this Standard.

### 19.3 Certificate Distribution

19.3.1 At the time of delivery of each ambulance, the Contractor shall provide a copy of;

- (1) the ambulance model certificate signed by the Director of the Emergency Health Regulatory and Accountability Services Branch that accompanies each ambulance sold for use in Ontario, and
- (2) a completed Compliance Checklist (Annex C or Annex D as appropriate for the individual ambulance being sold).

### 19.4 Non-Compliant Vehicles

19.4.1 Each ambulance supplied as a non-compliant ambulance at the request of the Purchaser shall have a certificate that,

- (1) is annotated as “Non-Compliant Vehicle– See Attached”, and
- (2) specifically sets out the areas of non-compliance in Part II.

19.4.2 Where an ambulance is non-compliant, the Operator prior to being placed into service shall ensure that:

- (1) the areas of non-compliance are rectified; and
- (2) all documentation and testing information is retained on file.

## 19.5 Continued Compliance

19.5.1 The Operator shall ensure that the ambulance maintains its compliance with the applicable version of the *Standard*.

19.5.2 Any subsequent modifications or changes made to the ambulance shall be in accordance with the version of the *Standard* in effect at the time of the modification or change.

Where modifications or changes occur to components or materials that require testing under the Performance Standards the Operator shall;

- (1) ensure that new testing is undertaken and completed, and
- (2) maintain on file all documentation related to the new testing information and confirmation of compliance with respect to the modified or changed ambulance.

19.5.3 The documentation described in section 19.5.2(2) shall be made available for inspection by the Ministry.

## 19.6 Compliance Review Program

19.6.1 The Ministry shall maintain a program for the purpose of monitoring the Contractor's compliance with the requirements under this *Standard*.

- 19.6.2 The program shall include site visits to the Contractor's production facilities at times while manufacturing and/or performance standard testing of ambulances intended for use in Ontario is occurring or at such other reasonable times as determined by the Director.
- 19.6.3 To aid in scheduling Ministry compliance reviews, the Contractor shall regularly provide the Director with a minimum of 60 calendar days' notice prior to commencing conversion or testing of ambulances being produced for use in Ontario.
- 19.6.4 The Contractor shall make available to designated Ministry personnel, for inspection and review, all documentation relating to the production and certification testing of ambulances being produced for use in Ontario.
- 19.6.5 Where the Contractor employs sub-contractors, testing agencies or consultants to provide goods or services, the process described in sub-sections 19.6.2 and 19.6.3 shall apply.
- 19.6.6 The Contractor shall arrange access for Ministry personnel to the facilities of its sub-contractors, testing agencies or consultants to observe activities relating to the manufacturing and/or performance standard testing of ambulances intended for use in Ontario.

## 19.7 Revocation and Suspension of an Ambulance Certification

- 19.7.1 The Director may revoke or suspend an ambulance model certification where:
- (1) a revision to, or a new version of, the *Standard* requires new testing certification of any Performance Standards listed in sub-sections 19.2.4 or 19.2.5;

- (2) the Contractor fails to provide required notification, documentation and/or access to production and testing facilities as described in sub-section 19.6; or
- (3) the Director is of the view that the Contractor has contravened any requirement under this Standard.

19.7.2 The Director may revoke or suspend an individual ambulance certification where:

- (1) a revision to, or a new version of, the *Standard* requires new testing certification of any Performance Standards listed in sub-sections 19.2.4 or 19.2.5;
- (2) the Operator fails to provide required documentation and/or testing information and/or access to production and testing facilities as described in sub-section 19.5.3; or
- (3) the Director is of the view that the Operator has contravened any requirement under this Standard.

## 19.8 Fees

The Director may establish fee schedules relating to the recovery of travel expenses from the Contractor, and any other costs associated with the provision of ambulance model certification and compliance monitoring.

## 20. AMBULANCE PERFORMANCE STANDARDS

### 20.1 Main Cot Retention

#### 20.1.1 Scope:

This performance standard establishes MOH minimum requirements and permits Vendors to set maximum load tolerances for the Main Cot retention systems as installed in single and dual Main Cot ambulances.

#### 20.1.2 Requirements:

20.1.2.1 The Main Cot retention system, anchorages and stretcher fastener(s) shall not fail or release when subjected to a minimum load application of 10x (the weight of the cot hardware, intended cot + a 90% male per the current CCHS data) applied in a horizontal plane in a longitudinal, lateral and vertical direction. (Note: these are three individual tests).

20.1.2.2 Each Main Cot retention system shall be labelled,  
(1) in clear view of the attending paramedic; and  
(2) label shall refer to ambulance certification documentation for permitted weight rating.

20.1.2.3 Testing shall be certified by a Professional Engineer registered and eligible to practice in Ontario according to the Professional Engineers Act.

#### 20.1.3 Test Conditions:

20.1.3.1 The ambulance floor shall be in a horizontal plane.

20.1.3.2 If the ambulance is designed to transport multiple Main Cots, the Main Cot retention system shall be tested in each location.

20.1.3.3 If adjustable, the Main Cot retention system shall be adjusted to its most forward position.

#### 20.1.4 Test Procedure:

20.1.4.1 Testing shall be conducted in accordance with the following procedures:

- (1) apply the specified force through the hook(s) (or other cot securing means) used in locking onto the cot using the test device;
- (2) install the test device in the Main Cot retention system in a manner that will preclude contact friction with the floor or other surfaces;
- (3) apply an initial vertical upward load to the test device pivot;
- (4) as rapidly as possible, apply the fully specified force to the device;
- (5) record the applied force, start and finish times and any deformation of the floor, cabinetry or retention mechanism;
- (6) release the applied load. If any deformation has occurred in the Main Cot retention system, replace the damaged parts. Note: rotation or deformation of retention mechanism does not constitute failure;
- (7) reinstall test fixture and repeat above steps in the longitudinal and again in the lateral direction; and
- (8) record all resultant data.

#### 20.1.5 Test Equipment:

20.1.5.1 The test shall be conducted using a testing device,

- (1) with a structure of appropriate design to represent the attachment points of a Main Cot; and
- (2) used for locking onto the hook(s) (or other cot securing means) of the Main Cot retention system.

20.1.5.2 The force shall be applied through a pivot located 380 mm above the floor, at a point representing the centre of the Main Cot.

## 20.2 Static Load Test for Ambulance Body Structures

### 20.2.1 Scope:

This performance standard establishes performance requirements for ambulance body structural integrity and is applicable to all ambulances where: a) modifications are made to OEM roofs, and/or; b) the body is manufactured by the Contractor.

### 20.2.2 Definitions:

"Converted Curb Weight" means the actual weight of the vehicle with all standard OEM equipment; carrying its maximum capacity of fuel, oil and coolant and including the weight of the conversion and all equipment as supplied by the Contractor in accordance with the terms of this Standard.

### 20.2.3 Requirements:

- 20.2.3.1 Where for Type II ambulances a force equal to 1.5 times the Converted Curb Weight of the vehicle, and for Types I and III ambulances a force equal to 2.5 times the Converted Curb Weight of the vehicle is applied to the roof of the vehicle's body structure through a force application plate, the downward vertical movement at any point on the application plate shall not exceed 100 mm.
- 20.2.3.2 Each exterior exit door of the vehicle shall be capable of opening during the full application of the force and after the release of the force.
- 20.2.3.3 No structural or component damage, such as torn or broken material, broken welds, popped or sheared rivets, bolts or fasteners shall be evident during the application of the force and after the release of the force.

- 20.2.4 Where for Types I and III ambulances a force equal to 2.5 times the Converted Curb Weight of the vehicle is applied to the left or right side of the body structure through a force application plate, the downward vertical movement at any point on the application plate shall not exceed 100 mm.
- 20.2.4.1 The rear exit doors of the vehicle shall be capable of opening during the full application of the force and after the release of the force.
- 20.2.4.2 No structural or component damage, e.g., torn or broken material, broken welds, popped or sheared rivets, bolts or fasteners shall be evident during the application of the force and after the release of the force.
- 20.2.4.3 Testing shall be certified by a Professional Engineer registered and eligible to practice in Ontario according to the Professional Engineers Act.
- 20.2.5 The test procedure designed for 20.2.3 shall be conducted in the following manner:
- (1) place the vehicle on a rigid horizontal surface so that the vehicle is entirely supported by means of the vehicle frame without any support from the suspension system. If the vehicle is constructed without a frame, place the vehicle on its body sill;
  - (2) remove any components which extend upwards from the vehicle roof;
  - (3) A modular body may be tested off of the chassis it's intended for, in which case the following applies:
    - (a) the module shall be placed on I beams to simulate the chassis frame; and
    - (b) the total weight applied shall still include 2.5 times the total Converted Curb Weight of the finished ambulance;
  - (4) Apply a rigid, rectangular force application plate fitted as near as possible to the contour of the ambulance roof;

- (5) Position the force application plate on the vehicle roof so that its rigid surface is perpendicular to a vertical longitudinal plane and so that in the top projected view, its longitudinal centreline coincides with the longitudinal centreline of the vehicle, and it is centred on the roof of the vehicle;
- (6) with all doors fully closed, apply an evenly distributed vertical force in the downward direction to the force application plate at any rate not more than 13 mm per second, until a force of 225 kg has been applied;
- (7) record the elevation readings of all four (4) corners of the force application plate;
- (8) apply additional vertical force in the downwards direction to the force application plate at a rate not more than 13 mm per second until 50% of the specified force has been applied and record the elevation readings of all four (4) corners;
- (9) continue to apply a vertical force to the application plate until the total force specified is applied and record elevation readings of all four (4) corners;
- (10) with the total load applied, test all doors for compliance with paragraph 20.2.3.2 and record the results;
- (11) remove the applied load from the application plate and record elevation readings at all four (4) corners of the roof;
- (12) compare results with the original readings to determine permanent deformation of the roof;
- (13) test all doors for compliance with paragraph 20.2.3.2; and
- (14) record the results.

20.2.6 The test procedure designed for 20.2.4 shall be conducted as follows:

- (1) place the body on either side, on a rigid horizontal surface so that the entire body is supported;
- (2) apply a rigid, rectangular force application plate fitted as near as possible to the contour of the ambulance side;

- (3) position the force application plate on the side of the vehicle so that its rigid surface is perpendicular to a vertical longitudinal plane and so that in the top projected view, its longitudinal centreline coincides with the longitudinal centreline of the vehicle, and it is centred on the side of the vehicle;
- (4) with all doors fully closed, apply an evenly distributed vertical force in the downward direction to the force application plate at any rate not more than 13 mm per second, until a force of 225 kg has been applied;
- (5) record elevation readings of all four (4) corners of the force application plate;
- (6) apply additional vertical force in the downwards direction to the force application plate at a rate not more than 13 mm per second until 50% of the specified force has been applied and record the elevation readings of all four (4) corners;
- (7) continue to apply a vertical force to the application plate until the total force specified is applied and record elevation readings of all four (4) corners;
- (8) with the total load applied, test rear doors for compliance with paragraph 20.2.4.1 and record the results;
- (9) remove the applied load from the application plate and record the elevation readings at all four (4) corners of the roof;
- (10) Compare the results with the original readings to determine permanent deformation of the side;
- (11) test the rear doors for compliance with paragraph 20.2.4.1; and
- (12) Record the results.

#### 20.2.7 Test Equipment:

The test shall be conducted using a flat, rigid rectangular force application plate that is,

- (1) measured with respect to the vehicle's roof or side longitudinal and lateral centrelines; and

- (2) a minimum of 130 mm longer and 130 mm wider than the ambulance roof /side. For the purposes of these measurements, the ambulance roof/side is that structure, seen in the top projected view that coincides with the patient compartment of the ambulance or storage area of the support vehicle.

### 20.3 HVAC Performance Tests

#### 20.3.1 Scope:

This performance standard establishes three (3) separate performance requirements for the Heating, Ventilation and Air conditioning (HVAC) Systems of ambulances.

#### 20.3.2 HVAC Requirements:

20.3.2.1 Each ambulance shall be equipped with HVAC systems that,

- (1) can be made to collectively operate using recirculated air and ambient air; and
- (2) are capable of maintaining interior temperature within the established comfort zone of 20°C to 25°C when operating between minus (-) 30°C to plus (+) 35°C ambient.

20.3.2.2 Vehicles shall be supplied as tested.

#### 20.3.3 Heating System Requirements:

20.3.3.1 The heating system(s) shall have sufficient capacity to simultaneously raise the temperature in the vehicle cab and patient compartment to a minimum dry bulb temperature of 20°C, at all 10 test points (9 in patient compartment and one in cab), within 30 minutes of the powertrain reaching operating temperatures.

20.3.3.2 The temperature gradient within the nine thermocouples in the patient compartment shall not exceed 5°C at completion of the test.

#### 20.3.4 Heating System Test Procedure:

- 20.3.4.1 In the patient compartment the nine (9) thermocouples, in stacks of three, shall be positioned as follows:
- (1) The horizontal axis shall be located at the centreline of the vehicle chassis and one stack each of three thermocouples shall be located at the one quarter, mid and three-quarter point distances between the rear doors and bulkhead; and
  - (2) In the vertical plane, one thermocouple shall be located at the one quarter, mid and three-quarter point distances between the finished floor and the underside of the ceiling in each stack.
- 20.3.4.2 Heating equipment may be in (air) recirculation mode and all compartment openings, including partition door/windows and exhaust vents shall be closed.
- 20.3.4.3 The vehicle (with doors open) shall be cold soaked for a sufficient period so as to obtain a temperature reading of  $-30^{\circ}\text{C} +2.5^{\circ}\text{C}$ , in both compartments and that temperature held to the commencement of the time measurement (i.e., EV start or powertrain at operating temperature). Ambient temperature must be maintained as close to  $-30^{\circ}\text{C} +2.5^{\circ}\text{C}$  as practical.
- 20.3.4.3.1 If the vehicle is powered by an internal combustion engine, start engine with transmission in park or neutral, allow engine to come up to operating temperature range as specified by the OEM, then run at the high idle setting, as permitted by the OEM, and commence time measurement.

20.3.4.4 Time and temperatures shall be recorded from nine (9) equally spaced test thermocouples in the patient compartment and a single test thermocouple located at the horizontal and vertical planes in the vehicle. At a minimum, verification readings shall be recorded at each noted time interval until the test is successfully completed or failure is declared after a 30-minute mark:

- (1) at vehicle start time;
- (2) powertrain at operating temperature range or when the reading at one or more thermocouples raises to  $-27.5^{\circ}\text{C}$  (start of test time measurement);
- (3) 15-minute mark (or pass); and
- (4) 30-minute mark (or pass).

20.3.5 Testing shall be certified by a Professional Engineer registered and eligible to practice in Ontario according to the Professional Engineers Act.

#### 20.3.6 Air Conditioning System Requirements:

20.3.6.1 The air conditioning system(s) shall have sufficient capacity to simultaneously lower the temperature at midpoints of the driver and patient compartments to a maximum dry bulb temperature of  $23^{\circ}\text{C}$  within 30 minutes of the vehicle being started.

20.3.6.2 The temperature gradient within the patient compartment shall not exceed  $5^{\circ}\text{C}$  at completion of the test.

#### 20.3.7 Air Conditioning Test Procedure:

20.3.7.1 The vehicle (with doors open) shall be heat soaked for a sufficient period so as to obtain a temperature of  $+35^{\circ}\text{C}$  /  $-2.5^{\circ}\text{C}$  in both compartments and that temperature held to commencement of the time measurement (i.e., EV or engine start). Ambient temperature must be maintained as close to  $+35^{\circ}\text{C}$  +/-  $2.5^{\circ}\text{C}$  as practical.

- 20.3.7.1.1 If the vehicle is powered by an internal combustion engine, the engine is started, and allowed to run at high idle setting while the transmission is in park or neutral and commence time measurements.
- 20.3.7.2 A minimum of two verification readings of time and temperature shall be recorded (vehicle start time, 15-minute mark (or pass), and final time) at thermocouple placement as specified in paragraph 20.3.4.1.
- 20.3.7.3 Air conditioning equipment may be in air recirculation mode and all compartment openings, including partition doors/windows shall be closed.
- 20.3.7.4 The test shall be conducted with a coolant system charge that does not exceed pressures recommended by the OEM.
- 20.3.7.4.1 If the OEM coolant system has been added to or modified, then the system pressure at start and finish of the test shall be recorded.
- 20.3.7.5 Testing shall be certified by a Professional Engineer registered and eligible to practice in Ontario according to the Professional Engineers Act.
- 20.3.8 Ventilation System Requirement:
- 20.3.8.1 Ventilation system(s) shall be,
- (1) capable of providing a complete change of ambient air within the vehicle every 2.5 minutes with the vehicle static; and
  - (2) separately controlled within each compartment.
- 20.3.8.2 Testing shall be certified by a Professional Engineer registered and eligible to practice in Ontario according to the Professional Engineers Act.

## 20.4 Pressure Vessel Retention

### 20.4.1 Scope:

This performance standard specifies requirements for mounts and brackets that restrain pressure vessels including all oxygen tank holders, fire extinguisher brackets and mounts for tanks containing pressurized gases installed in ambulances or support vehicles. This is a two-part procedure: (a) tests that the bracket designed to hold the pressure vessel can withstand a 25G force and (b) the bracket mounting can withstand 10 times the weight of the bracket + 25 times the weight of a fully loaded tank(s) which the tank holder was designed to restrain. These tests can be performed together or separately and shall be documented as such with specific details of mounting hardware and locations.

### 20.4.2 Definitions:

"Tank Holder" means the retention system, including all hardware provided for holding the pressure vessel (tank) in the ambulance or support vehicle.

### 20.4.3 Requirements:

20.4.3.1 When a force equal to 25 times the weight of a fully loaded tank(s) which the tank holder was designed to restrain, plus the weight of the tank holder is applied to the tank holder, as specified in section 20.4.4,

- (1) the tank holder components shall not fail and/or separate along attachment points;
- (2) the tank holder or any component thereof shall not separate from the vehicle at any attachment point; and
- (3) the force application cylinder shall not disengage from the tank holder.

20.4.3.2 When a force equal to 25 times the weight of a fully loaded tank(s) which the tank holder was designed to restrain, plus 10 times the weight of the tank holder is applied to the tank holder, as specified in section 20.4.4,

- (1) the tank holder or any component thereof shall not separate from the vehicle at any attachment point; and
- (2) the part of the vehicle to which the tank holder is attached shall not fail and/or separate at any attachment point.

20.4.3.3 Testing shall be certified by a Professional Engineer registered and eligible to practice in Ontario according to the Professional Engineers Act.

#### 20.4.4 Test Procedure:

20.4.4.1 Each tank holder shall be capable of meeting the specified requirements when tested in accordance with the following procedures:

- (1) Using the installed tank holder, insert the force application cylinder and apply the forces specified below (the forces do not need to be applied simultaneously):
  - (a) the 25 G force to either end of the cylinder so that the action of the force coincides with the longitudinal centreline of the cylinder, in each plane; and
  - (b) the 25 G force to the cylinder in any direction, in a plane perpendicular to the longitudinal centreline of the cylinder and which passes through the location which corresponds to the location of the centre of gravity of a full tank, for which the holder is designed to restrain.

- (2) Using the installed tank holder, apply the forces specified below (the forces do not need to be applied simultaneously):
- (a) a force equal to 25 times the weight of a fully loaded tank(s) which the tank holder was designed to restrain, plus 10 times the weight of the tank holder so that the action of the force coincides with the longitudinal centreline of the cylinder, in each plane; and
  - (b) a force equal to 25 times the weight of a fully loaded tank(s) which the tank holder was designed to restrain, plus 10 times the weight of the tank holder in a plane perpendicular to the longitudinal centreline of the cylinder and which passes through the location which corresponds to the location of the centre of gravity of a full tank, for which the holder is designed to restrain.

20.4.4.2 The ambient temperature shall be between 0°C and 35°C.

20.4.5 Test Equipment:

The test shall be conducted using a force application cylinder that has,

- (1) a rigid structure; and
- (2) the same physical dimensions as the cylinder that the tank holder was designed to restrain.

20.5 Interior Sound Level Test

20.5.1 Scope:

This performance standard establishes maximum interior sound levels for the patient compartment and the cab of ambulances.

20.5.2 Requirements:

20.5.2.1 The interior sound level in the patient compartment shall not exceed 80 decibels (dB) when measured in accordance with this test performance standard.

20.5.2.2 The interior sound level in the driver compartment shall not exceed 84 decibels (dB) with the cab windows closed or 90 decibels (dB) with the cab windows open 150 mm when measured in accordance with this test performance standard.

20.5.2.3 Testing shall be certified by a Professional Engineer registered and eligible to practice in Ontario according to the Professional Engineers Act.

20.5.3 Test Conditions:

20.5.3.1 Vehicle doors, windows and vents shall be in the closed position.

20.5.3.2 Air conditioner/heater blower switch in patient and/or driver compartments shall be placed at the highest speed.

20.5.3.3 If the vehicle is powered by an internal combustion engine, the motor vehicle's engine radiator fan drive is equipped with a clutch or similar device that automatically either reduces the rotational speed of the fan or completely disengages the fan from its power source in response to reduced engine cooling loads, the vehicle may be parked before testing with its engine running at high idle or any other speed that the Operator chooses for sufficient time, but not more than 10 minutes, to permit the engine radiator fan to automatically disengage.

20.5.3.4 Siren and all warning lights shall be turned on for full duration of each test, with the siren sounding in the loudest mode of operation.

20.5.3.5 The driver shall be in their normal seated driving position.

20.5.3.6 The person conducting the test shall be the only other person in the vehicle.

20.5.3.7 This test shall be performed during the following weather conditions:

- (1) ambient temperature shall be within a range of 0°C - 30°C;
- (2) Wind velocity shall not exceed 18 km/hr;
- (3) Other meteorological conditions shall be such that they do not influence the measurements; and
- (4) Ambient temperatures, speed and direction of wind related to the vehicle's positioning shall be recorded, including the date, start and finish time of testing.

20.5.4 Test Procedure:

Testing shall be conducted in accordance with the following procedures:

- (1) suspend the microphone vertically 150 mm above the normal position of the patient's head on the primary Main Cot;
- (2) park the vehicle at a location so that no large reflecting surfaces, such as other vehicles, signboards, buildings or hills are within 15 metres of the vehicle being tested;
- (3) if the vehicle is powered by an internal combustion engine, set the vehicle transmission in neutral gear and accelerate engine to 50 to 60 percent of the engine manufacturer's RPM rating. Stabilize the engine at that speed and measure the highest sound level;
- (4) If the vehicle is powered by an internal combustion engine, return engine speed to idle and repeat the process as specified above.
- (5) two maximum sound levels within 2 decibels (dB) of each other is recorded. Numerically average these two maximum sound level readings. A 2 dB tolerance over the specified sound level limits is permitted to allow for variations in test conditions and capabilities of meters.

- (6) repeat the above requirements in the driver compartment by suspending the microphone at a point 150 mm below the interior headliner mid-way between the seated positions of the driver and passenger; and
- (7) repeat the above requirements in the driver compartment with both the driver and passenger side windows open 150 mm.
- (8) Record results

#### 20.5.5 Test Equipment:

The test shall be conducted using a sound level meter that meets the OH&S requirements of a type 2-meter operating on the A-weighting network with a slow meter response.

## 20.6 Vehicle Weight Distribution

### 20.6.1 Scope:

This performance standard establishes requirements for distribution of the weight of an ambulance.

### 20.6.2 Definitions:

20.6.2.1 “gross vehicle weight rating” or “GVWR” means GVWR as defined in the Canadian Motor Vehicle Act and Regulations;

20.6.2.2 “curb weight” means curb weight as defined in the Canadian Motor Vehicle Act and Regulations;

20.6.2.3 “gross axle weight rating” or “GAWR” means GAWR as defined in the Canadian Motor Vehicle Act and Regulations;

20.6.2.4 "Converted Curb Weight" means the actual weight of the vehicle with all standard OEM equipment; carrying its maximum capacity of fuel, oil and coolant and including the weight of the conversion and all equipment as supplied by the Contractor in accordance with the terms of this Standard; and

20.6.2.5 "Payload Allowance" means the actual weight difference determined by the subtraction of the 'Converted Curb Weight' from the 'Gross Vehicle Weight Rating'. The minimum required 'Payload Allowances' for each ambulance configuration is set out in sub-section 18.1 of this Standard.

20.6.3 Requirements:

20.6.3.1 The Converted Curb Weight distribution of a properly loaded ambulance, on a level surface, shall be such that not less than thirty percent, and not more than fifty percent of the vehicle's weight is on the front suspension.

20.6.3.1.1 Where the OEM specifies a weight distribution that differs from the above,  
(1) the conversion shall conform to that requirement; and  
(2) the Contractor shall retain a copy of the OEM specification with the test results.

20.6.3.2 The Converted Curb Weight on the right and left wheel of each axle of the completed vehicle shall be weighed to determine weight distribution.

20.6.3.2.1 The weight between each side shall be:  
(1) within five percentage points; and  
(2) calculated as follows:  
(a) obtain the converted curb weight of each wheel on a given axle;  
(b) divide the weight of each wheel by the total converted curb weight of the axle, times (x) 100 = percentage of weight on each side;  
(c) subtract the smaller percentage from the larger result; and

- (d) if the difference is five percentage points or less, the vehicle has complied with the required weight distribution.

20.6.3.3 The vendor shall complete the following information and submit it with the test certificate:

(1) Gross Vehicle Weight Rating \_\_\_\_\_ kg

(2) Chassis Curb Weight Distribution:

(a) Chassis Curb Weight \_\_\_\_\_ kg

(b) Front Axle

(i) Gross Axle Weight Rating \_\_\_\_\_ kg

(ii) Chassis Curb Axle Weight \_\_\_\_\_ kg

(iii) Chassis Curb Left Side Wt. \_\_\_\_\_ kg

(iv) Chassis Curb Right Side Wt. \_\_\_\_\_ kg

(c) Rear Axle

(i) Gross Axle Weight Rating \_\_\_\_\_ kg

(ii) Chassis Curb Axle Weight \_\_\_\_\_ kg

(iii) Chassis Curb Left Side Wt. \_\_\_\_\_ kg

(iv) Chassis Curb Right Side Wt. \_\_\_\_\_ kg

(3) Converted Curb Weight Distribution:

(a) Front Axle

(i) Converted Curb Axle Weight \_\_\_\_\_ kg

(ii) Converted Curb Left Side Wt \_\_\_\_\_ kg

(iii) Converted Curb Right Side Wt \_\_\_\_\_ kg

(b) Rear Axle

(i) Converted Curb Axle Weight \_\_\_\_\_ kg

(ii) Converted Curb Left Side Wt \_\_\_\_\_ kg

(iii) Converted Curb Right Side Wt \_\_\_\_\_ kg

(c) Converted Curb Weight \_\_\_\_\_ kg

(d) Payload (GVWR - Converted Curb Wt.) \_\_\_\_\_ kg

(4) Calculations:

(a) Front/Rear weight distribution calculated as per paragraph 20.6.3.1

Percent weight on front axle = \_\_\_\_\_%

(b) Front axle left/right weight distribution per paragraph 20.6.3.2

Percent difference side to side = \_\_\_\_\_%

(c) Rear axle left/right weight distribution per paragraph 20.6.3.2

Percent difference side to side = \_\_\_\_\_%

20.6.3.4 Ballast shall not be used to achieve proper weight distribution.

20.6.3.5 The ambient temperature shall be between 0°C and 35°C.

20.6.3.6 Testing shall be certified by the Contractor.

## 20.7 Centre of Gravity Location:

### 20.7.1 Scope:

This performance standard establishes requirements for the location of the Actual Centre of Gravity (ACG) of an ambulance.

### 20.7.2 Requirements:

20.7.2.1 The Contractor shall calculate the location of the ACG of the fully converted ambulance.

- 20.7.2.2 The Contractor shall certify that the ACG is,
- (1) at or below the maximum height as set out by the chassis manufacturer; and
  - (2) in compliance with the longitudinal and lateral limits set by the chassis manufacturer.
- 20.7.2.3 Ballast shall not be used to achieve proper location of the ACG.
- 20.7.2.4 The ambient temperature shall be between 0°C and 35°C.
- 20.7.2.5 Testing shall be certified by a Professional Engineer registered and eligible to practice in Ontario according to the Professional Engineers Act.

## 20.8 12 Volt dc Electrical System Performance

### 20.8.1 Scope:

This performance standard establishes performance requirements and certification criteria for the 12 Volt dc electrical systems of ambulances.

### 20.8.2 Application:

To meet this performance standard,

- (1) Each ambulance shall be tested; and
- (2) a certificate explaining the results shall be presented to the Purchaser at the time of delivery

### 20.8.3 Requirements:

- 20.8.3.1 The generating system shall produce the maximum required output at the regulated voltage.
- 20.8.3.1.1 If powered by an internal combustion engine, the engine RPM shall not exceed the OEM recommended high idle speed.

20.8.3.2 The test certificate that is presented to the Purchaser shall confirm that,

- (1) the ambulance was tested as delivered; and
- (2) the generating system is capable of supporting the mandatory continuous current loads as per the requirements of this performance standard.

20.8.3.3 If the ambulance is equipped with a 12V dc load management system, then the ambulance shall be tested in the condition which imposes the maximum electrical current load while the load management system is operating

20.8.3.4 The certificate in paragraph 20.8.3.2 shall clearly state:

- (1) the maximum load was restricted by a load management system; and
- (2) which electrical functions listed in paragraph 20.8.4.1 were turned off or altered by the load management system in order to restrict the load.

20.8.3.5 Testing shall be certified by the Contractor.

#### 20.8.4 Test Procedures:

20.8.4.1 For the purpose of this test, the following systems (loads), turned on simultaneously, shall constitute the maximum required output referred to in paragraph 20.8.3.1:

- (1) ignition system;
- (2) headlights (low beam) and all CMVSS running lights;
- (3) windshield wipers (low speed);
- (4) cab air conditioning (at coldest setting with highest blower speed);
- (5) 2-way radio in receive mode (or 5-amp load if radio not installed);
- (6) patient compartment ceiling lighting (on high setting);
- (7) patient compartment air conditioning (at coldest setting with highest blower speed);
- (8) emergency warning light system on primary mode and wig-wags on;
- (9) 10-amp medical load or equal;

- (10) left and right scene lights; and
- (11) rear scene light.

- 20.8.4.2 Ammeters shall be installed to measure the maximum load imposed on the generating system.
- 20.8.4.3 Voltmeters shall be installed to separately monitor the voltage of each battery (or bank of batteries)
- 20.8.4.4 The vehicle shall be started and set in a condition (in compliance with paragraph 20.8.3.1.1) which will maintain the voltage at all batteries between 12.5 and 15 volts for the duration of the test.
- 20.8.4.5 If the vehicle is powered by an internal combustion engine, The vehicle shall be run for fifteen minutes prior to start of test period.
- 20.8.4.5.1 All the loads listed in paragraph 20.8.4.1 shall be turned on and the test period shall begin.
- 20.8.4.5.2 The test period shall be fifteen minutes.
- 20.8.4.6 The ammeter reading(s) (in amps) shall be recorded at the following intervals:
- (1) the start of the test;
  - (2) the 7 minute mark; and
  - (3) the 15 minute mark.
- 20.8.4.7 The voltage at each battery or battery bank shall be monitored for the duration of the test.
- 20.8.4.7.1 The highest and lowest voltage reading of each battery or battery bank shall be recorded.

20.8.4.7.2 At minimum the readings shall be conducted at the following intervals:

- (1) the start of the test;
- (2) the 7 minute mark; and
- (3) the 15 minutes mark.

20.8.4.8 Subsequent to 12 Volt DC Electrical System Performance test, all added optional components shall be identified by their amperage load with a “not to exceed” caution label indicating the maximum amperage to maintain battery reserve.

#### 20.8.5 Test Conditions:

20.8.5.1 The ambulance shall be complete and ready for delivery including all equipment as specified by the Purchaser.

20.8.5.2 All batteries shall be fully charged.

20.8.5.3 Ambient temperature shall be a minimum of 17°C.

20.8.5.3.1 Actual ambient temperature shall be recorded.

20.8.5.4 If the vehicle is powered by an internal combustion engine, the under hood maximum temperature reached shall be recorded.

#### 20.9 Intentionally Deleted

#### 20.10 Antennae Ground Plane Test

##### 20.10.1 Antenna Ground Plane:

20.10.1.1 The antenna ground planes shall be checked by the Contractor to ensure that they are properly grounded to the chassis of the vehicle.

- 20.10.2 The resistance between the ground plane and the chassis frame shall not exceed one ohm.
- 20.10.3 The resistance between the ground plane and the negative battery shall not exceed 0.5 ohms.
- 20.10.4 Testing shall be certified by the Contractor.

## 20.11 Interior Lighting Test

### 20.11.1 Scope:

This performance standard establishes the minimum interior illumination level for the patient compartment of ambulances.

### 20.11.2 Requirements:

Normal illumination within the patient compartment shall not be less than:

- (1) 160 Lux (lx) measured along the centreline of the clear walking path at floor level located in the area between the rear and side doors; and
- (2) 376 lx on at least 90% of the surface area of the Main Cot(s).

- 20.11.2.1 These limits shall be achieved without outside ambient light and with the Patient Compartment lights operating at the "high" setting.
- 20.11.2.2 The ambient temperature shall be between 0°C and 35°C.
- 20.11.2.3 Testing shall be certified by a Professional Engineer registered and eligible to practice in Ontario according to the Professional Engineers Act.

### 20.11.3 Test Procedures

20.11.3.1 Testing shall be conducted using the following procedures:

- (1) with the cot installed and top of the cot marked into squares not larger than 150mm x 150mm, record readings from the centre of each square (see dia. 1);
- (2) with the cot installed measure along centreline of the walking path between rear and side door openings, at minimum, there shall be 10 readings along the path evenly spaced (see dia. 1), record the readings.

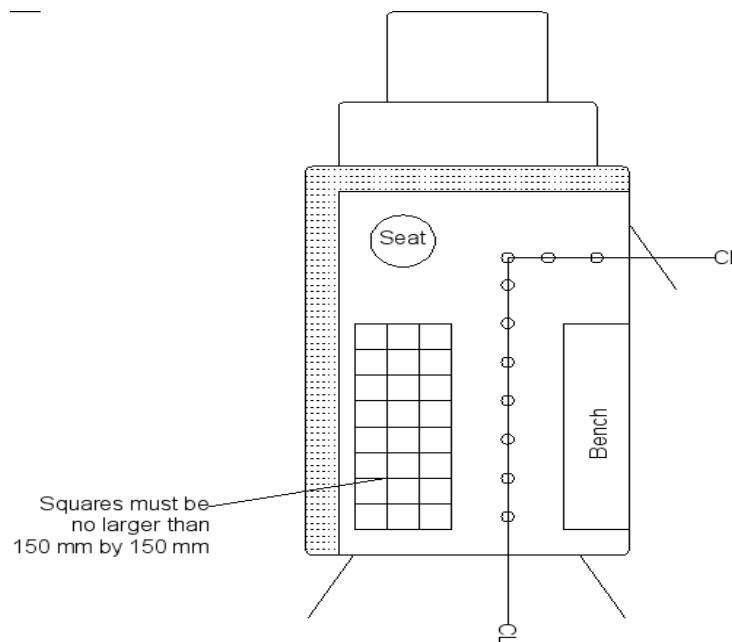

## 20.12 Oxygen System Pressure Test

### 20.12.1 Scope:

This performance standard establishes the test requirements for the on-board oxygen system.

### 20.12.2 Requirements:

20.12.2.1 Each ambulance shall be tested.

20.12.2.1.1 A certificate shall be presented to the Purchaser at the time of delivery.

20.12.2.2 Testing shall be certified by the Contractor.

### 20.12.3 Test Procedure:

20.12.3.1 Testing shall be conducted in accordance with the following procedures:

- (1) When system is completed, a cylinder of medical air, nitrogen gas or equal with pressure regulator set to delivery 552 kPa will be connected to the oxygen system inlet. Turn the cylinder on to pressurize the system and inspect all joints for leaks. Correct any leaks noted.
- (2) Attach a pressure gauge (0-1380 kPa) securely to the oxygen outlet at the action area(s)
- (3) Pressurize the system to 552 kPa and turn off the cylinder leaving it attached to the inlet connector for a minimum of 120 minutes. No drop in system pressure is allowed.
- (4) After successful completion of testing, the system shall be capped with plastic end caps and tagged with a certificate tag showing the:
  - (a) start time;
  - (b) initial pressure;
  - (c) end time;
  - (d) final pressure;
  - (e) date; and
  - (f) signature of tester.

20.13 *Intentionally Deleted*

20.14 *Intentionally Deleted*

### 20.15 Body Door Components Test

#### 20.15.1 Scope:

This performance standard establishes requirements for the testing of all body door retention components on the side entry door and rear door(s) as installed.

### 20.15.2 Application:

This performance standard shall apply to all ambulances when the side entry and/or rear doors are supplied and installed by someone other than the OEM.

### 20.15.3 Requirements:

20.15.3.1 Each door shall be tested and certified for compliance to CMVSS 206 and all other relevant CMVSS Regulations.

20.15.3.2 The ambient temperature shall be between 0°C and 35°C.

20.15.3.3 Testing shall be certified by a Professional Engineer registered and eligible to practice in Ontario according to the Professional Engineers Act.

## 20.16 Emergency Lighting Requirements

### 20.16.1 Scope:

This performance standard establishes minimum performance of an individual emergency warning light and the primary emergency lighting system.

### 20.16.2 Requirements:

20.16.2.1 Each individual emergency light utilized as part of the primary emergency lighting system shall meet or exceed SAE J845 'Optical Warning Devices for Authorized Emergency, Maintenance, and Service Vehicles'.

20.16.2.2 The primary emergency light system shall be measured and certified to meet or exceed per requirement set as set in,

- (1) this Standard document;
- (2) SAE J2498 sections 1 to 5 inclusive; and
- (3) SAE J2498 sections 6.2 and 7 of 'Minimum Performance of the Warning Light System used on Emergency Vehicles.'

20.16.2.3 The minimum optical requirements for any size of vehicle shall be as stated in the table below;

Zones	Level	Zone Total at H	Min. Value at Any H Point	Min. Value at Any +/-5° Point
A	Upper	1,000,000	10,000	3,500
B	Upper	400,000	10,000	3,500
C	Upper	800,000	10,000	3,500
D	Upper	400,000	10,000	3,500
A	Lower	150,000	3,750	1,300

NOTE: All values are in candela-seconds/minute.

H = Horizontal plane passing through the centre of the light source.

20.16.2.4 The following shall be the Permissible Colours by zone while primary emergency lights are in operation:

<u>Colour</u>	<u>Zones</u>
Red	Any Zone
White	Any Zone
Blue	A Upper, B, C and D
Yellow	Not Permitted
Green	Not Permitted

20.16.2.5 Testing shall be certified by a Professional Engineer registered and eligible to practice in Ontario according to the Professional Engineers Act.

### 20.16.3 Test Reports:

At minimum, the test reports shall include:

- (1) a detailed layout of light locations on the vehicle;
- (2) details of each light that is part of the primary circuit including make, part number and colour;
- (3) detailed flash rate and pattern;
- (4) detailed switching parameters;
- (5) a separate list of equivalent substitutions by location; and
- (6) a clear statement of compliance to SAE J845, relevant sections of J2498 and this Standard.

## 20.17 Carbon Monoxide Levels

### 20.17.1 Scope:

This performance standard establishes performance requirements for maximum levels of concentration of carbon monoxide (CO).

### 20.17.2 Requirements:

- 20.17.2.1 The CO content in the ambient air and the vehicle shall be determined through a series of operating performance test periods.
- 20.17.2.2 The resultant difference between the highest readings in each of the three (3) operating states and the average ambient condition shall not exceed 10 ppm of CO.
- 20.17.2.3 Testing shall be certified by a Professional Engineer registered and eligible to practice in Ontario according to the Professional Engineers Act.

### 20.17.3 Test Conditions:

- (1) Calibrate equipment at the start of test.
- (2) Open vehicle doors and auxiliary windows and ventilate with fresh air for 10 minutes with the engine off.
- (3) Do not conduct testing during high wind periods (above 25 kph) or during any type of precipitation.

### 20.17.4 Test Procedure:

20.17.4.1 The test shall be conducted in accordance with the following procedures.

20.17.4.1.1 Detail how meter was calibrated at start of test and confirm at end.

20.17.4.1.2 Sample and record the ambient air around the vehicle.

20.17.4.1.3 If the vehicle has an internal combustion engine, start and idle the engine in parked position for 10 minutes of 20.17.4.1.4 measurements.

20.17.4.1.4 Close the windows and doors, perform following measurements:

- (1) monitor and record the CO in the driver compartment, around the doors, windows, floor, engine cowling and openings from engine compartment for the first 5 minutes;
- (2) monitor and record the CO in patient compartment, at head of Main Cot for the remaining 5 minutes.

20.17.4.1.5 Drive the vehicle for 10 minutes on traffic laden city streets (urban speeds of 30 to 60 kph);

- (1) repeat sampling during drive time as stated in paragraphs 20.17.4.1.4 (a and b) and;
- (2) record the results.

20.17.4.1.6 Drive the vehicle for 10 minutes at highway speeds of 80 to 100 kph,  
(1) repeat sampling during drive time as stated in paragraphs 20.17.4.1.4 (1) and;  
(2) record the results.

20.17.4.1.7 Stop the vehicle and repeat paragraph 20.17.4.1.2.

20.17.4.1.8 Confirm calibration of meter at end of test, record results.

#### 20.17.5 Test Equipment:

20.17.5.1 The test shall be conducted using a MSA Model I or Model II CO monitor or equivalent instrument with an accuracy of +/- 4%.

### 20.18 Load Test for Grab Rail/Handles

#### 20.18.1 Scope:

This performance standard establishes the minimum static load requirements for all grab rails and grab handles.

#### 20.18.2 Requirement:

20.18.2.1 A grab rail and grab handle shall not detach or loosen during the load application of 227 kg in noted directions.

20.18.2.2 The ambient temperature shall be between 0°C and 35°C.

20.18.2.3 Testing shall be certified by a Professional Engineer registered and eligible to practice in Ontario according to the Professional Engineers Act.

### 20.18.3 Test Procedure - Grab Rail:

20.18.3.1 The test shall be conducted in accordance with the following procedures:

- (1) with the vehicle parked on a flat surface, measure the grab rail for straightness and the space between top sides of rail and headliner or supporting cabinetry;
- (2) attach a force application device to the grab rail at a midpoint between two securing points and incrementally apply the required load in a plane parallel to the fasteners for the rail;
- (3) hold the load for two (2) minutes and release;
- (4) repeat paragraph 20.18.3.1(2 and 3) at least one other midpoint between two securing points;
- (5) repeat the above test procedures applying the load perpendicular to the initial plane; and;
- (6) examine and measure the grab rail for loosening or bending and record the results.

### 20.18.4 Test Procedure - Grab Handles:

20.18.4.1 The test shall be conducted in accordance with the following procedures:

- (1) attach a force application device to the midpoint of the grab handle and incrementally apply the required load in a plane parallel to the fasteners for the handle;
- (2) hold the load for two (2) minutes and release;
- (3) repeat the test procedures applying the load perpendicular to the initial plane;
- (4) examine the grab handle for loosening and record the results.

20.18.4.2 The above test procedures shall be completed for each different material the grab handles are secured to

## 20.19 Siren/Public Address System Sound Levels

### 20.19.1 Scope:

This performance standard establishes the minimum sound level output for the siren / public address system.

### 20.19.2 Requirements:

- 20.19.2.1 The siren shall be capable of producing a continuous warning sound that is,
- (1) at a minimum level of 123 dBA in “wail” mode,
  - (2) A-weighted,
  - (3) at 3 meters,
  - (4) on axis,
  - (5) capable of producing a continuous warning sound at a minimum level of 122 dBA in “yelp” mode, and
  - (6) at a frequency in the range of 500 to 2000 Hz maximum.
- 20.19.2.2 If the vehicle is powered by an internal combustion engine, record RPM used during test (RPM shall not exceed 60% of the OEM recommended high idle speed).
- 20.19.2.3 Testing shall be certified by a Professional Engineer registered and eligible to practice in Ontario according to the Professional Engineers Act.

### 20.19.3 Test Conditions:

- 20.19.3.1 Vehicle doors, windows and vents shall be in the closed position.
- 20.19.3.2 The siren shall be sounded in its loudest mode of operation.

- 20.19.3.3 This test shall be performed during the following meteorological conditions:
- (1) ambient temperature shall be within range of 0°C to 30°C;
  - (2) wind velocity shall not exceed 18 km/hr and;
  - (3) other meteorological conditions, e.g., rain, fog, etc. shall be such that they do not influence the measurements.

20.19.4 Test Procedure:

- 20.19.4.1 The test shall be conducted in accordance with the following procedures:
- (1) position the meter on a horizontal plane three (3) meters forward of the centreline of the vehicle's hood and one meter above ground level;
  - (2) park the vehicle at a location so that no large reflecting surfaces, such as other vehicles, signboards, buildings or hills are within 15 metres of the vehicle being tested;
  - (3) two maximum sound levels within 2 decibels (dB) of each other is recorded. Numerically average these two maximum sound level readings.
  - (4) if the vehicle is powered by an internal combustion engine, it is permitted to set the vehicle transmission in neutral gear and accelerate engine to 50 to 60 percent of the engine manufacturer's RPM rating;
  - (5) turn on the siren and measure the highest sound level;
  - (6) if the vehicle is powered by an internal combustion engine, return the engine speed to idle and repeat the process as specified above until two (2) maximum sound levels within two (2) decibels (dB) of each other are recorded; and
  - (7) numerically average these two (2) maximum sound level readings.
  - (8) Record RPM used during test.
  - (9) Record voltage at conversion battery.
  - (10) ambient temperature, speed and direction of wind related to the vehicle's positioning shall be recorded.
  - (11) record the date, start and finish time of testing.

#### 20.19.5 Test Equipment:

The test shall be conducted using a sound level meter that meets the OH&S requirements of a type 2 meter operating on the A-weighting network with a slow meter response.

### 20.20 Incubator Restraint Load

#### 20.20.1 Scope:

This performance standard establishes performance requirements for the incubator rear tie-down fixture(s).

#### 20.20.2 Requirements:

20.20.2.1 The incubator rear tie-down fixtures(s) shall not detach, loosen or deform during the application of a force of 1,360kg

20.20.2.2 The ambient temperature shall be within range of 0°C to 35°C;

20.20.2.3 Testing shall be certified by a Professional Engineer registered and eligible to practice in Ontario according to the Professional Engineers Act.

#### 20.20.3 Test Procedure:

20.20.3.1 The test load shall be applied forward and upward at an angle of 45 degrees above the plane of the ambulance floor.

20.20.3.2 Examine and measure the rear tie-down fixture(s) for compliance.

## 20.21 Passenger and Patient Safety Restraints Load

### 20.21.1 Scope:

This performance standard establishes requirements for passenger and patient safety restraints.

### 20.21.2 Requirements:

20.21.2.1 All seat belts and seats installed by the Contractor for the use of seated passengers shall be tested and certified for compliance to CMVSS 207, 208, 209, 210 and all other relevant CMVSS regulations.

20.21.2.1.1 Where there is no regulation under CMVSS (such as a side-facing seat) the material and design shall meet the spirit of CMVSS regulations for passenger restraint.

20.21.2.1.2 All installations shall be tested to the relevant CMVSS standards.

20.21.2.2 Seat belts installed by the Contractor to restrain patients shall be tested and certified to the intent of CMVSS 210 by the application of a total force of 2267 kg divided equally between the seat belt assemblies.

20.21.2.3 The ambient temperature shall be between 0°C and 35°C.

20.21.2.4 Testing shall be certified by a Professional Engineer registered and eligible to practice in Ontario according to the Professional Engineers Act.

## 20.22 10 G restraint test

### 20.22.1 Scope:

This performance standard establishes the minimum static load requirements for securing equipment or material weighing over 14kg (30lbs) within the vehicle.

### 20.22.2 Requirements:

20.22.2.1 When a force equal to 10 times the total weight of the intended equipment or material, and the weight of the restraint is applied to the restraint then:

- (1) the restraint shall not fail and/or separate along attachment points; and
- (2) the restraint or any component thereof shall not separate from the vehicle at any attachment point.

20.22.2.2 The ambient temperature shall be between 0°C and 35°C.

20.22.2.3 Testing shall be certified by a Professional Engineer registered and eligible to practice in Ontario according to the Professional Engineers Act.

### 20.22.3 Test Procedure:

20.22.3.1 The test shall be conducted in accordance with the following procedures:

- (1) attach a force application device to the restraint and incrementally apply the required load in a plane parallel to the fasteners;
- (2) repeat the test procedures applying the load perpendicular to the initial plane;
- (3) examine the restraint and record the results.

20.22.3.2 The above test procedures shall be completed for each different material the restraint is secured to.

## 20.23 Occupant Restraint Load Test

### 20.23.1 Scope:

This performance standard establishes the minimum static load requirements for the occupant restraint device and its fasteners.

### 20.23.2 Requirements:

20.23.2.1 Fasteners shall be tested and certified to withstand a force by the application of a total force of 2268kg divided equally between the fasteners securing occupant device.

20.23.2.2 The occupant restraint device installed at side facing seats by the Contractor to comply with this standard shall be tested and certified to withstand a force of 1361kg.

20.23.2.3 The ambient temperature shall be between 0°C and 35°C.

20.23.2.4 Testing shall be certified by a Professional Engineer registered and eligible to practice in Ontario according to the Professional Engineers Act.

### 20.23.3 Test Procedure - Fasteners:

20.23.3.1 The test shall be conducted in accordance with the following procedures:

- (1) attach a force application device to the fastener, apply the required load in a plane parallel to the fastener;
- (2) repeat the test procedures applying the load perpendicular to the initial plane; and
- (3) examine the fastener(s) and record the results.

20.23.3.2 The above test procedures shall be completed for each different material the fastener is secured to.

#### 20.23.4 Test Procedure - occupant restraint

20.23.4.1 The test shall be conducted in accordance with the following procedures:

- (1) apply a force in a forward direction at the centre of the device using a suitable solid block to distribute the load; and
- (2) examine the restraint device and fastener(s) and record the results.

#### 20.24 Occupant Head Protection Zone

##### 20.24.1 Scope:

This test establishes the minimum acceptable dimension for an occupant seating position.

##### 20.24.2 Purpose:

To ensure the measurement of the occupant's head protection zone is performed correctly for all makes and models of ambulances.

##### 20.24.3 Definitions:

20.24.3.1 "Seating position" means any seating space that provides a seat belt to restrain the occupant.

20.24.3.2 "Head protection zone" means the space above a seating position that is to be free of contact surfaces.

20.24.3.3 “Test Fixture” is a ridged rectangular structure weighing not more than 27kg and has the following dimensions, 1093mm (43”) high x 458mm (18”) wide x 381mm (15”) deep (All dimensions have a tolerance of +/- 2mm). The Test Fixture is to be clearly marked, with TOP and FRONT as illustrated in figure #1.

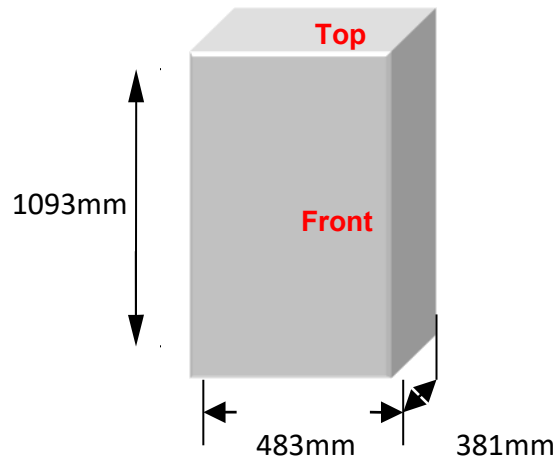

Figure #1

20.24.4 Requirements:

20.24.4.1 Each seating position within the patient’s compartment shall be validated using the Test Fixture.

20.24.4.2 Pictures shall form part of the test report for each seating position.

20.24.4.3 Testing shall be certified by the Contractor.

20.24.5 Test procedure:

20.24.5.1 The test is conducted in accordance with the following procedures:

- (1) the vehicle shall be parked on a level surface;
- (2) all seating positions shall have finished cushions installed;

- (3) for each seating position, place the Test Fixture, top up, onto the seat, with the front of the Test Fixture facing the direction of the intended occupant;
- (4) the Test Fixture shall not overhang the front of the seat cushion, unless it is a Type 2 ambulance and it is not a contact surface within the head protection zone set out in section 20.24.3.2.
- (5) no permanent objects shall not be in contact with the Test Fixture;
- (6) the test shall be documented; and
- (7) the test results shall be recorded.

## **Annex A – Emergency Response Vehicle Requirements**

### **A1 SCOPE:**

Annex A describes the minimum acceptable requirements for Emergency Response Vehicles (ERV) intended for use in ambulance services in the Province of Ontario.

### **A2 DEFINITIONS:**

A2.1 "Emergency Response Vehicle" (ERV) shall have the same meaning as defined in Ontario regulation 257/00 and the vehicles that are recognized as ERVs under this Standard shall consist of the following:

- (1) "ERV - responder" means a vehicle that responds on a regular basis to emergency medical incidents.
- (2) "ERV support" means an equipment and supply carrier that responds to support ambulance service operations at major emergency medical incidents.
- (3) "ERV command" means a vehicle that responds to provide operational command and control functions for major emergency medical incidents.

### **A3 GENERAL REQUIREMENTS:**

A3.1 Each ERV shall comply with the following documents, listed in order of precedence:

- (1) the Canadian Motor Vehicle Safety Standards (CMVSS);
- (2) applicable sections of the HTA;
- (3) Except where exemptions apply, the applicable sections of the Ontario Provincial Land Ambulance & Emergency Response Vehicle Standard (the Standard);
- (4) any criteria established by the OEM for the conversion of chassis to Emergency Response Vehicles; and
- (5) all relevant Standards and Recommended Practices of technical agencies and bodies referred to in this Standard.

- A3.2 Each ERV shall comply with the version of the documents listed in section A3.1 that were in effect at the time that the manufacturing of the ERV was completed.
- A3.3 Each ERV shall be,
- (1) constructed with the operating accessories as required herein; and
  - (2) furnished with such modifications and attachments as may be necessary to enable the vehicle to function reliably and efficiently in its intended operating environment.
- A3.4 Each ERV certified for use in Ontario under previous versions of the *Standard* shall be deemed to continue to be certified under the current version until sold or modified in contravention of the version in effect at the time of the change.
- A3.5 When an ERV is equipped with 110v electrical power,
- (1) each outlet shall have an indication that power to the outlet(s) is present.
  - (2) such installations shall be completed in accordance with relevant Ontario law governing 110v installations in vehicles.
  - (3) all electrical installation shall be inspected and approved by an inspector certified under relevant Ontario law.
  - (4) an approved seal or certificate shall be affixed adjacent to the installation.

**A4 EXTERIOR IDENTIFICATION:**

- A4.1 The exterior markings and design of an **ERV – responder** vehicle shall readily identify the vehicle as an Emergency Response Vehicle to all observers.
- A4.1.1 This identification, in conjunction with the activated emergency warning systems shall alert the public to the purpose and need to yield the right of way to this vehicle.

- A4.2 The exterior markings and design of an **ERV – support** vehicle shall readily identify the vehicle as an Emergency Response Vehicle to all observers. This identification, in conjunction with the activated emergency warning systems shall alert the public to the purpose and need to yield the right of way to this vehicle.
- A4.3 Each **ERV - command** vehicle shall comply with the certified ambulance service’s municipally approved Visual Identification Program and may with the written authorization of the municipality be exempt from exterior markings as identified in A.4.1.1.

## **A5 EMERGENCY WARNING SYSTEM**

### A5.1 Design Parameters

- A5.1.1 The emergency lighting system shall utilize flashing lights.
- A5.1.2 Subject to exemptions set out below, the emergency lighting system design shall abide by the following principles:
- (1) white (i.e. clear) light or blue light will be used to gain the viewer's attention;
  - (2) red light will convey the "emergency" message;
  - (3) amber light will convey the "caution" message;
  - (4) no colour other than red, white, blue and amber shall be used;
  - (5) any flashing lights of the same light type (e.g. incandescent, halogen strobe or Neobe®) and colour shall flash simultaneously, then alternate to the other colour along the same side and plane; and
  - (6) amber lights(s) shall not flash at the same time as other emergency lights facing in the same direction.

A5.1.3 The following shall be exemptions to the emergency lighting system design in section A5.1.3;

- (1) the white grille lights (Wig Wags), which are not required to flash in or with any other lights on the vehicle;
- (2) traffic directional devices;
- (3) red or amber stop turn signalling devices required under the HTA; and
- (4) inside exterior door warning lights.

A5.1.4 The emergency lighting system shall be comprised of components and devices that comply with the requirements of SAE J576, J578, J591, J595, J1318 and J1889 as applicable to the unit.

A5.1.5 The primary emergency lighting system shall achieve all criteria and performance testing standards as set out in section 20 of the *Standard*.

A5.1.5.1 The primary emergency lighting system shall be,

- (1) wired to operate independently of the other warning lights; and
- (2) controlled by a separate switch on the driver's console.

A5.1.6 The primary emergency lights shall include:

- (1) 360-degree warning lights;
- (2) Grille lights; and
- (3) Intersection lights.

A5.2 360 Degree Warning Lights

A5.2.1 Each Emergency Response Vehicle (ERV) shall be equipped with an array of red and either white or blue flashing lights installed on the front, sides, and rear of the ERV which are visible for 360 degrees around the vehicle.

A5.2.1.1 This array shall include a minimum of two (2) red and one (1) white or blue light in each direction.

A5.2.1.2 The red light(s) shall be in the extreme upper outer corner unless the light head utilizes LEDs that perform the function of both red and white or blue.

A5.3 Grille Lights

A5.3.1 Each ERV shall have grille lights installed on the vertical plane of the grille such that:

- (1) the location is in compliance with OEM considerations regarding air flow through the grille;
- (2) the lights are visible in the rear-view mirror(s) of a passenger car preceding the ERV;
- (3) there are two (2) red lights; and
- (4) there are two (2) white lights (Wig Wags) (which may be the high beam of the OEM headlights when permitted by the OEM) which flash in an alternating or random sequence.

A5.3.1.1 With respect to subsection A5.3.1(4), when an alternating pattern is selected of the same type light as the red emergency grille lights, the flash rate shall be,

- (1) faster;

- (2) wired to operate independently of the other warning lights; and
- (3) controlled by a separate switch on the driver's console.

A5.4 Intersection Lights

A5.4.1 Red and either white or blue intersection lights shall be installed at each of the front lower corners of each ERV.

A5.5 Siren - Public Address System

- A5.5.1 Each ERV shall have a combination siren and public address system that,
- (1) is capable of producing high/low horn tones and other warning sounds;
  - (2) is complete with a microphone and speaker; and
  - (3) achieves all criteria as detailed in section 20 of the Standard.

A5.6 Backup Warning Alarm

Each ERV shall have a heavy-duty reverse warning signal that operates when the gear selector is in "REVERSE".

A5.6.1 Where a disable switch is installed, this switch shall be programmed to reset automatically prior to the lapse of 60 seconds from the time the switch is disabled.

**A6 2-WAY RADIO INSTALLATIONS:**

A6.1 General

A6.1.1 Each ERV design shall provide for the installation of radio equipment.

A6.1.2 The term "radio equipment" shall include all peripheral equipment associated with the radio, including:

- (1) a mobile radio unit which consists of the mobile radio transceiver or the FleetNet mobile radio repeater package;
- (2) the front control head, microphone and speaker;
- (3) all associated antennas
- (4) cables between the control head, speaker, mobile radio unit, battery and antenna and;
- (5) portable radio

A6.2 Radio Equipment Mounting

A6.2.1 Each ERV shall have a designated area for mounting radio equipment to ensure uninterrupted operation that:

- (1) provides adequate access for installation or removal and periodic maintenance;
- (2) provides protection from physical damage; and
- (3) is ventilated.

A6.2.2 A mounting position shall be provided for the radio control head and microphone clip in the driver's area that allows equal access for both the driver and passenger and does not impede the OEM line of sight out of the vehicle.

A6.2.3 The mounting of radio equipment shall not:

- (1) interfere with other control functions;
- (2) block vents;
- (3) block the line of sight for gauges or instruments;
- (4) interfere with air bag type passenger restraint systems; or
- (5) encroach into the paramedic seating area.

A6.3 Antenna Ground Plane

A6.3.1 Where the ERV is equipped with a non-metallic roof, an antenna ground plane that is a minimum of 1 square metre shall be moulded into the roof.

A6.3.2 The ground plane shall,

- (1) be grounded to the vehicle frame; and
- (2) meet criteria as detailed in section 20 of this Standard.

A6.3.3 To enable installation of an antenna mount, the total thickness of the roof and ground plane shall not exceed 10 mm for a 75 mm diameter circle at each antenna mount point.

A6.3.4 At each antenna mount point, the lower surface of the ground plane shall be exposed to enable contact with the antenna mount.

#### A6.4 Cable Routing

A6.4.1 Cables to radio equipment shall be protected from wear and damage. This may include any or all of the following:

- (1) passages between sections of cabinetry;
- (2) fixed conduits with a minimum inside dimension of 75x50 mm; and
- (3) removable channels with a minimum inside dimension of 60x35 mm.

A6.4.2 Maximum cable routing length between the radio control head and mobile radio unit shall not exceed 5.2m (17ft).

#### A6.5 Installation of Radio Equipment

A6.5.1 All radio equipment shall be installed so that all fasteners and other means of attachment used in the installation or relocation into the ERV provide a minimum restraining force of at least 10 times the weight of the component and/or object being secured.

A6.5.2 All attachments shall be fastened in a manner that will preclude unintentional loosening.

A6.5.3 Mounting of radio equipment shall not:

- (1) interfere with other control functions;
- (2) block vents or instruments; or
- (3) interfere with air bag passenger restraint systems , and;
- (4) does not impede the OEM line of sight out of the vehicle

**A7 STORAGE:**

- A7.1 Each ERV shall be designed with adequate storage arrangements to safely contain the minimum mandatory equipment specified by the PES.
- A7.1.1 Each ERV shall have one (1) fire extinguisher that is,
- (1) 5lb C-UL approved;
  - (2) rating 3-A, 10 BC; and
  - (3) rechargeable type with pressure gauge and service inspection tag.
- A7.2 All equipment or material carried in the cab or passenger compartment of an ERV shall be appropriately secured to ensure the safety of the occupants.
- A7.2.1 All storage compartments, securing straps, brackets and cargo nets shall be capable of retaining at least 10 times the total weight of component, fasteners, equipment, or material they are designed to restrain.
- A7.3 All oxygen cylinder cradles, and fire extinguisher brackets shall be designed and mounted to comply with all criteria for pressure vessel retention as set out in section 20 in the *Standard*.

**A8 INTERIOR SIGNS AND LABELS:**

- A8.1 All weight related labels shall,
- (1) contain the maximum weight rating;
  - (2) be located in such a way that does not restrict the occupant's ability view; and
  - (3) indicate weights in both lbs and kg.

A8.2 Each ERV shall have the following labels;

- (1) each pressure vessel holder shall be labelled with the type, size of tank(s) and maximum weight of tank(s) it is intended to restrain,
- (2) Radio equipment mounting location(s) as defined in section A6.1.2 (1) and (2);
- (3) accessory receptacles and other electrical outlets shall be labelled with their intended use (e.g.12V, 20amp or 110VAC 15amp); and
- (4) each storage area, securing strap, bracket and/or cargo net

**A9. CERTIFICATION OF AN EMERGENCY RESPONSE VEHICLE:**

A9.1 Prior to being in service, every new ERV model intended to be used in the Province shall be certified in accordance with this *Standard* by the Director.

A9.1.2 The process for Ministry certification of an ERVs may include site visits to the Contractor's production and testing facilities at times when the Director determines that manufacturing or performance standard testing of an ERV intended for use in Ontario is occurring.

A9.1.3 To facilitate the site visits described in section A9.1.2, the Contractor shall:

- (1) provide the Director with a minimum of 60 calendar days notice prior to commencing testing of ERVs;
- (2) If the Contractor is International, proof of the vehicles admissibility into Canada shall be required.

- A9.1.4 Certification of a vendor shall,
- (1) be done by ERV type as defined in A2.1, and
  - (2) remain valid until such time as determined solely by the Director, EHRAB.
- A9.1.5 The Contractor shall apply for certification of an ERV type by submitting the following documentation:
- (1) a letter signed by the Contractor stating that the ERV type as offered for use in the Province of Ontario is in compliance with all provisions of this Standard;
  - (2) a copy of all test certificates and technical reports required for the Performance Standards (Section 20);
  - (3) if applicable a copy of the "Ministerial Authorization" for the use of the National Safety Mark issued by Transport Canada relevant to the model for Canadian Contractors.
  - (4) a completed copy of Annex E noting compliance with specified sections of the Standard, signed by an officer of the Contractor, dated and notarised; and
  - (5) included with the test submission shall be model or part numbers of products tested and a pictorial record of the tests;
- A9.1.6 Each ERV type certification will be granted solely at the discretion of the Director and shall be in writing.
- A9.1.7 Each ERV individual test certificates shall remain valid for a maximum of four (4) years so long as they are applicable to the vehicle model, component(s) and equipment offered as tested under this *Standard*.

- A9.1.7.1 After the expiry of the four (4) year period, and subject to sub-section A9.1.8, the test certificate then shall require recertification.
- A9.1.8 In lieu of recertification of a test, a Contractor may make application to the Director of the Emergency Health Regulatory and Accountability Branch to have the term of an individual test certificate extended for an additional period of two years from the original test date.
- A9.1.8.1 This application shall,
- (1) be completed prior to expiry of original certificate; and
  - (2) include a detailed argument, based on sound engineering principles, explaining why the extension should be granted.
- A9.1.9 Extensions shall be,
- (1) granted solely at the discretion of the Director; and
  - (2) in writing.
- A9.1.9.1 A maximum of one (1) extension shall be allowed for any individual certification.
- A9.2 If an Ambulance is converted or its primary purpose is to be used as an ERV, then,
- (1) only those areas modified to fit this new role shall require certification; and
  - (2) the remainder of the unit shall be deemed to be in compliance with the Standard and Annex A, providing the ownership remains unchanged and the word ambulance is removed or covered.

A9.3 Certificates and Reports

A9.3.1 The Contractor shall,

- (1) retain on file the original copy of all currently valid test certificates required under the Performance Standards set out in section 20 of this Standard; and
- (2) complete technical reports in support of those certificates.

A9.3.2 Each individual test certificate shall clearly state:

- (1) the number and title and date of revision of the Performance Standard;
- (2) the date and location when the test was performed;
- (3) the name of the company or organization which completed the test;
- (4) the name and title of the person who has verified the test results complete with signature (and proof of License for the engineer);
- (5) that the test requirements were passed;
- (6) the chassis type(s) and ERV type(s) for which the certificate is valid;
- (7) the make, model, year and Vehicle Identification Number of the tested chassis;
- (8) the make, model, type and year of the tested ERV conversion;
- (9) the make, model, and other identifying marks on any components being tested or that make up systems which are being tested; and
- (10) the make, model, and other identifying marks on any components being tested or that make up systems which are being tested and include photographs and/or diagrams that clearly distinguish the components or systems for future reference.
- (11) a unique test certificate reference number.

A9.3.3 Each technical report held in support of a test certificate shall contain at minimum:

- (1) all information required on the test certificate;
- (2) all data collected in performance of the test including any descriptive or explanatory notes, pictures, videos;
- (3) a description of equipment and facilities used to perform the tests; and
- (4) next calibration due date.

A9.3.4 The following tests shall be completed by a Licensed Ontario Professional Engineer and certified as conforming to these Performance Standards.

- (1) Pressure Vessel Retention (20.4);
- (2) Interior Sound Level Test (20.5);
- (3) Centre of Gravity Location (20.7);
- (4) Body Door Components Test (20.15);
- (5) Emergency Lighting Requirements (20.16);
- (6) Carbon Monoxide Levels (20.17);
- (7) Load Test for Grab Rail/Handles (20.18);
- (8) Siren/Public Address System Sound Levels (20.19);
- (9) 10G Restraint Test (20.22)

A9.3.5 The following tests shall be completed by the Contractor and certified as conforming to these Performance Standards.

- (1) Antenna System Test (20.10);

A9.4 Certificate Distribution

A9.4.1 At the time of delivery of each ERV, the Contractor shall provide a copy of:

- (1) ERV type certificate signed by the Director;
- (2) a completed Annex E Compliance Checklist,

A9.4.2 Non-Compliant Vehicles

A9.4.2.1 Each ERV supplied as a non-compliant ERV at the request of the Purchaser shall have a certificate that;

- (1) is annotated as “Non-Compliant Vehicle– See Attached”, and
- (2) specifically sets out the areas of non-compliance in Part II of Annex E.

A9.4.3 Where an ERV is non-compliant, the Operator prior to being placed into service shall ensure that:

- (1) the areas of non-compliance are rectified; and
- (2) retain on file all documentation and testing information.

A9.5 Continued Compliance

A9.5.1 The Operator shall ensure that the ERV maintains its compliance with the applicable version of the *Standard*.

A9.5.2 Any subsequent modifications or changes made to the ERV shall be in accordance with the version of the *Standard* in effect at the time of the modification or change.

A9.5.3 Where modifications or changes occur to components or materials that require testing under the Performance Standards, the Operator shall ensure that new testing is undertaken and completed.

- A9.5.4 The Operator shall maintain on file,
- (1) all necessary documentation;
  - (2) new testing information; and
  - (3) confirmation of compliance with respect to the modified or changed ERV.
- A9.5.4.1 The information specified in A9.6.4 shall be made available for inspection by the Ministry.
- A9.6 Compliance Review Program
- A9.6.1 The Ministry shall maintain a program for the purpose of monitoring the compliance of the Contractor with the requirements under this Standard.
- A9.6.2 The program shall include site visits to the Contractor's production facilities at times while manufacturing and/or performance standard testing of ERVs intended for use in Ontario is occurring or at such other reasonable times as determined by the Director.
- A9.6.3 To aid in scheduling Ministry compliance reviews the Contractor shall regularly provide the Director with a minimum of 60 calendar days' notice prior to commencing conversion or testing of ERVs being produced for use in Ontario.
- A9.6.4 The Contractor shall make available to designated Ministry personnel, for inspection and review, all documentation relating to the production and certification testing of ERVs being produced for use in Ontario.

- A9.6.5 Where the Contractor employs sub-contractors, testing agencies or consultants to provide goods or services,
- (1) the process described in sub-sections A9.7.2 and A9.7.3 shall apply; and
  - (2) the Contractor shall arrange access for Ministry personnel to the facilities of its sub-contractors, testing agencies or consultants to observe activities relating to the manufacturing and/or performance standard testing of ERVs intended for use in Ontario.

A9.7 Revocation and Suspension of an ERV Certification

A9.7.1 The Director may revoke or suspend an ERV type certification where:

- (1) a revision to, or a new version of, the Standard requires new testing certification of any Performance Standards listed in sub-section A9.3.4 or A9.3.5;
- (2) the Contractor fails to provide required notification, documentation and/or access to production and testing facilities as described in sub-section A9.6.4 and A9.6.5; or
- (3) the Director is of the view that the Contractor has contravened any requirement under this Standard.

A9.7.2 The Director may revoke or suspend an individual ERV certification where:

- (1) a revision to, or a new version of, the Standard requires new testing certification of any Performance Standards listed in sub-section A9.3.4 or A9.3.5;
- (2) the Operator fails to provide required documentation and/or testing information and/or access to production and testing facilities as described in sub-section A9.6; or

- (3) the Director is of the view that the Operator has contravened any requirement under this Standard.

A9.8 Fees

- A9.8.1 The Director may establish fee schedules relating to the recovery of travel expenses from the Contractor, and any other costs associated with the provision of ambulance model certification and compliance monitoring.

## **Annex B - REMOUNTED AMBULANCE TRANSFER OF PATIENT COMPARTMENT MODULE**

### **B1. SCOPE:**

Annex B describes the minimum acceptable requirements for the remounting of patient compartment modules, removed from previously certified ambulances, on new or used chassis, intended for use in Ontario.

### **B2. GENERAL REQUIREMENTS:**

B2.1 Each Remount shall comply with the following documents, listed in order of precedence:

- (1) the Canadian Motor Vehicle Safety Standards (CMVSS);
- (2) Applicable sections of the HTA;
- (3) this Standard;
- (4) any criteria established by the OEM for the conversion of chassis to ambulances; and
- (5) all relevant SAE Standards and SAE Recommended Practises.

B2.2 The documents referenced in sub-section B2.1 shall be those documents that were in effect no earlier than when the motor vehicle chassis was manufactured and no later than when the vehicle was completed as a Remount.

B2.3 Each Remount shall be complete with the operating accessories as required herein, and furnished with such modifications and attachments as may be necessary to enable the vehicle to function reliably and efficiently in its intended operating environment.

B2.4 The design of the vehicle and the required equipment installations shall maximize the safety and security of the occupants.

B2.5 Each Remount shall be in compliance with all appropriate sections of the *Standard*.

**B3. STRUCTURAL INTEGRITY:**

The Contractor, prior to any other work taking place, shall verify the structural integrity of the patient compartment module.

**B4. MATERIAL CHANGES:**

B4.1 Seats, Seat Belts & Other Occupant Safety Restraints

B4.1.1 All seats in the patient compartment shall be replaced in accordance with applicable requirements under CMVSS, unless Transport Canada has given prior approval of an acceptable testing program that is in compliance with CMVSS.

B4.1.2 If Transport Canada has given prior approval of an acceptable testing program, replacements will be based on test results and the seats will not have to be replaced.

B4.1.3 All passenger seat belts in the patient compartment shall be replaced with new seat belts certified under CMVSS.

B4.1.4 Floor and other anchor points for seats, the occupant restraint device and the incubator rear tie-down fixture shall be inspected and, if necessary, replaced or reinforced in order to comply with the applicable CMVSS requirements and the ambulance performance tests contained in this Standard.

B4.1.5 All other patient safety restraints and equipment securing straps shall be inspected and, if necessary, replaced in order to comply with test restraint requirements in this Standard.

B4.1.6 Where seats, seat belts and/or other occupant restraints are replaced:

- (1) performance tests required under the Standard shall be completed; and
- (2) the results shall be submitted.

B4.2 Compartment Materials

Unless flammability-testing protocols have been approved by Transport Canada in accordance with CMVSS, all material shall either:

- (1) be in compliance with CMVSS 302; or
- (2) be replaced with material that is in compliance with the requirements of the CMVSS standard.

B4.3 Exterior Lights

B4.3.1 All “clearance lights” required under CMVSS shall be inspected and, if necessary, replaced with lamps/lights that are compliant with the requirements of CMVSS.

B4.3.2 All other exterior operating and emergency lights shall:

- (1) be inspected; and
- (2) if necessary upon inspection, the lamps, lens and reflectors replaced in order to comply with the CMVSS, the HTA and the photometric levels required under this Standard.

**B4.4**      Body Door Components

B4.4.1      All door frames, fasteners, hinges and door locks shall be inspected to ensure continued compliance with CMVSS.

B4.4.2      All replacement components shall also comply with this safety standard.

**B4.5**      Seat Travel

The mounting of the module on the chassis shall not alter the horizontal travel of the vehicle cab seat bases as manufactured by the OEM.

**B5.**      CERTIFICATION:

B5.1      Certification for a Remount model shall be in accordance with section 19 of the Standard.

B5.2      The Contractor shall inspect every patient compartment offered for Remount and submit to the Operator, a written statement as to whether or not there exists any condition that may cause the ambulance after Remount to not be in compliance with the current Performance Standards as detailed in the Standard and listed below:

- (1) Main Cot Retention;
- (2) Static Load Test for Ambulance Body Structures;
- (3) HVAC Performance Test;
- (4) Pressure Vessel Retention;
- (5) Interior Lighting;
- (6) Body Door Components Test;
- (7) Emergency Lighting Requirements;
- (8) Load Test for Grab Rail/Handles;
- (9) Passenger and Patient Safety Restraints Load Tests;
- (10) 10G restraint test;
- (11) Occupant Restraint Load Test; and
- (12) Occupant Head Protection Zone

- B5.2.1 Failure to correct noted deficiencies shall result in a non-compliant Remount.
- B5.3 The following tests shall be completed by a Licenced Ontario Professional Engineer and certified as conforming to the Performance Standards:
- (1) Interior Sound Level Test;
  - (2) Centre of Gravity Location;
  - (3) Carbon Monoxide Levels; and
  - (4) Siren/Public Address System Sound Levels.
- B5.4 The following tests shall be completed by the Contractor and certified as conforming to the Performance Standards:
- (1) Vehicle Weight Distribution;
  - (2) 12 Volt dc Electrical System Performance;
  - (3) Antenna System Test; and
  - (4) Oxygen System Pressure Test.
- B5.5 For Remounts of an identical type, the Contractor may request Compliance Certification for all like Remounts and complete actual testing only once for all the above Performance Standards. The exception being the 'Oxygen System Pressure Test' shall be completed for every Remount.

## Annex C – New Ambulance Compliance Checklist

### PART 1- COMPLIANCE CHECKLIST

This Checklist is to be completed in accordance with sub-section 19.1.4 of the *Standard* and submitted to the Director Emergency Health Regulatory and Accountability Branch along with the other required documentation for compliance certification. Compliance or non-compliance with each requirement will be noted by (✓). In instances where any non-compliance is noted, within a section the details of the non-compliance will be provided in the Part II including the sub-section number.

1. **Scope of the Standard** ..... Compliance ( ) Non-Compliance ( )
2. **Definitions** ..... Compliance ( ) Non-Compliance ( )
3. **General Requirements of the Ambulance** ..... Compliance ( ) Non-Compliance ( )
  - 3.7 110v Electrical Power ..... Compliance ( ) Non-Compliance ( )
4. **Ambulance Owners Manual** ..... Compliance ( ) Non-Compliance ( )
5. **Materials** ..... Compliance ( ) Non-Compliance ( )
6. **Exterior Identification** ..... Compliance ( ) Non-Compliance ( )
7. **Construction and Design Details** ..... Compliance ( ) Non-Compliance ( )
8. **Heating, Ventilation and Air Conditioning** ..... Compliance ( ) Non-Compliance ( )
9. **Low Voltage Conversion Electrical System** ..... Compliance ( ) Non-Compliance ( )
10. **Emergency Warning System** ..... Compliance ( ) Non-Compliance ( )
11. **2-Way Radio Installations** ..... Compliance ( ) Non-Compliance ( )
  - 11.6 Installation of radio equipment ..... Compliance ( ) Non-compliance ( )
12. **Oxygen System** ..... Compliance ( ) Non-Compliance ( )
13. **Suction Aspiration System** ..... Compliance ( ) Non-Compliance ( )
14. **Accommodation and Storage** ..... Compliance ( ) Non-Compliance ( )
15. **Safety Equipment** ..... Compliance ( ) Non-Compliance ( )
16. **Interior Signs and Labels** ..... Compliance ( ) Non-Compliance ( )

17. **Modular Ambulance Body - Type 1 and 3** ..... Compliance ( ) Non-Compliance ( )
18. **Ambulance Chassis Specifications** ..... Compliance ( ) Non-Compliance ( )
19. **Certification of an Ambulance Model** ..... Compliance ( ) Non-Compliance ( )
20. **Ambulance Performance Standards** ..... Compliance ( ) Non-Compliance ( )
- 20.1 Main Cot Retention ..... Compliance ( ) Non-Compliance ( )
- 20.2 Static Load Test Ambulance Body Structures ..... Compliance ( ) Non-Compliance ( )
- 20.3 HVAC Performance Tests ..... Compliance ( ) Non-Compliance ( )
- 20.3.3 Heating System ..... Compliance ( ) Non-Compliance ( )
- 20.3.6 Air Conditioning System ..... Compliance ( ) Non-Compliance ( )
- 20.3.8 Ventilation System ..... Compliance ( ) Non-Compliance ( )
- 20.4 Pressure Vessel Retention ..... Compliance ( ) Non-Compliance ( )
- 20.5 Interior Sound Level Test ..... Compliance ( ) Non-Compliance ( )
- 20.6 Vehicle Weight Distribution ..... Compliance ( ) Non-Compliance ( )
- 20.7. Centre of Gravity Location ..... Compliance ( ) Non-Compliance ( )
- 20.8 12 Vdc Electrical System Performance ..... Compliance ( ) Non-Compliance ( )
- 20.10 Antennae System ..... Compliance ( ) Non-Compliance ( )
- 20.11 Interior Lighting ..... Compliance ( ) Non-Compliance ( )
- 20.12 Oxygen System Pressure Test ..... Compliance ( ) Non-Compliance ( )
- 20.15 Body Door Components Test ..... Compliance ( ) Non-Compliance ( )
- 20.16 Emergency Lighting Requirements ..... Compliance ( ) Non-Compliance ( )
- 20.17 Carbon Monoxide Levels ..... Compliance ( ) Non-Compliance ( )
- 20.18 Load Test for Grab Handles/Rail ..... Compliance ( ) Non-Compliance ( )

- 20.19 Siren/Public Address System Sound Levels ..... Compliance ( ) Non-Compliance ( )
- 20.20 Incubator Restraint Load..... Compliance ( ) Non-Compliance ( )
- 20.21.2.1 All installed passenger seat belts.....Compliance ( ) Non-Compliance ( )
- 20.21.2.2 All installed patient restraint belts.....Compliance ( ) Non-Compliance ( )
- 20.22 10 G Restraint Test..... Compliance ( ) Non-Compliance ( )
- 20.23 Occupant Restraint Load Test..... Compliance ( ) Non-Compliance ( )
- 20.24 Occupant Head Protection Zone.....Compliance ( ) Non-Compliance ( )

## **PART II – NON-COMPLIANCE DETAILS**

Provide sub-section number and provide details. Attach additional information to the Checklist as required.

## **PART III – Components and options supplied by Contractor at time of delivery**

In this area Contractors are to list all components and options supplied on unit.

Attach additional information to the Checklist as required.

**Part IV - CONTRACTOR'S COMPLIANCE CERTIFICATION****Contractor's Name:** \_\_\_\_\_

I certify that this Annex to Version 7.0 of the 'Ontario Provincial Land Ambulance & Emergency Response Vehicle Standard' has been completed accurately and that all areas of non-compliance have been identified.

**Company Officer:**

\_\_\_\_\_

(Print Name)

\_\_\_\_\_

(Signature)

\_\_\_\_\_

(Date)

\_\_\_\_\_

(Notarized, required for ambulance model certification only)

\_\_\_\_\_

(Date)

**PART V- INDIVIDUAL AMBULANCE DETAILS****Vehicle Identification Number:** \_\_\_\_\_**MOH Compliance Certificate Number:** \_\_\_\_\_**Date of Completion (final inspection):** \_\_\_\_\_**Name of Purchaser:** \_\_\_\_\_

## ANNEX D - REMOUNTED AMBULANCES COMPLIANCE CHECKLIST

### PART I - COMPLIANCE DETAILS

This Checklist is to be completed in accordance with sub-section 19.1.4 of the Standard and submitted to the Director Emergency Health Regulatory and Accountability Branch along with the other required documentation for compliance certification. Compliance or non-compliance with each requirement will be noted by (✓). Where a requirement is not applicable (N/A) will be noted.

In instances where any non-compliance is noted within a section then details of the non-compliance will be provided in PART II including the sub-section number.

- |   |                                   |
|---|-----------------------------------|
| 1. <b>Scope of the Standard</b> .....                     | Compliance ( ) Non-Compliance ( ) |
| 2. <b>Definitions</b> .....                               | Compliance ( ) Non-Compliance ( ) |
| 3. <b>General Requirements of the Ambulance</b> .....     | Compliance ( ) Non-Compliance ( ) |
| 3.7 110v Electrical Power .....                           | Compliance ( ) Non-Compliance ( ) |
| 4. <b>Ambulance Owners Manual</b> .....                   | Compliance ( ) Non-Compliance ( ) |
| 5. <b>Materials</b> .....                                 | Compliance ( ) Non-Compliance ( ) |
| 6. <b>Exterior Identification</b> .....                   | Compliance ( ) Non-Compliance ( ) |
| 7. <b>Construction and Design Details</b> .....           | Compliance ( ) Non-Compliance ( ) |
| 8. <b>Heating, Ventilation and Air Conditioning</b> ..... | Compliance ( ) Non-Compliance ( ) |
| 9. <b>Low Voltage Conversion Electrical System</b> .....  | Compliance ( ) Non-Compliance ( ) |
| 10. <b>Emergency Warning System</b> .....                 | Compliance ( ) Non-Compliance ( ) |
| 11. <b>2-Way Radio Installations</b> .....                | Compliance ( ) Non-Compliance ( ) |
| 11.6 Installation of radio equipment .....                | Compliance ( ) Non-compliance ( ) |
| 12. <b>Oxygen System</b> .....                            | Compliance ( ) Non-Compliance ( ) |
| 13. <b>Suction Aspiration System</b> .....                | Compliance ( ) Non-Compliance ( ) |
| 14. <b>Accommodation and Storage</b> .....                | Compliance ( ) Non-Compliance ( ) |

15. **Safety Equipment** ..... Compliance ( ) Non-Compliance ( )
16. **Interior Signs and Labels** ..... Compliance ( ) Non-Compliance ( )
17. **Modular Ambulance Body - Type 1 and 3** ..... Compliance ( ) Non-Compliance ( )
18. **Ambulance Chassis Specifications** ..... Compliance ( ) Non-Compliance ( )
19. **Certification of an Ambulance Model** ..... Compliance ( ) Non-Compliance ( )
20. **Ambulance Performance Standards** ..... Compliance ( ) Non-Compliance ( )
- 20.1 Main Cot Retention ..... Compliance ( ) Non-Compliance ( )
- 20.2 Static Load Test Ambulance Body Structures ..... Compliance ( ) Non-Compliance ( )
- 20.3 HVAC Performance Tests ..... Compliance ( ) Non-Compliance ( )
- 20.3.3 Heating System ..... Compliance ( ) Non-Compliance ( )
- 20.3.6 Air Conditioning System ..... Compliance ( ) Non-Compliance ( )
- 20.3.8 Ventilation System ..... Compliance ( ) Non-Compliance ( )
- 20.4 Pressure Vessel Retention ..... Compliance ( ) Non-Compliance ( )
- 20.5 Interior Sound Level Test ..... Compliance ( ) Non-Compliance ( )
- 20.6 Vehicle Weight Distribution ..... Compliance ( ) Non-Compliance ( )
- 20.7. Centre of Gravity Location ..... Compliance ( ) Non-Compliance ( )
- 20.8 12 Vdc Electrical System Performance ..... Compliance ( ) Non-Compliance ( )
- 20.10 Antennae System ..... Compliance ( ) Non-Compliance ( )
- 20.11 Interior Lighting ..... Compliance ( ) Non-Compliance ( )
- 20.12 Oxygen System Pressure Test ..... Compliance ( ) Non-Compliance ( )
- 20.15 Body Door Components Test ..... Compliance ( ) Non-Compliance ( )
- 20.16 Emergency Lighting Requirements ..... Compliance ( ) Non-Compliance ( )

- 20.17 Carbon Monoxide Levels ..... Compliance ( ) Non-Compliance ( )
- 20.18 Load Test for Grab Handles/Rail ..... Compliance ( ) Non-Compliance ( )
- 20.19 Siren/Public Address System Sound Levels .....Compliance ( ) Non-Compliance ( )
- 20.20 Incubator Restraint Load..... Compliance ( ) Non-Compliance ( )
- 20.21.2.1 All installed passenger seat belts.....Compliance ( ) Non-Compliance ( )
- 20.21.2.2 All installed patient restraint belts.....Compliance ( ) Non-Compliance ( )
- 20.22 10 G Restraint Test..... Compliance ( ) Non-Compliance ( )
- 20.23 Occupant Restraint Load Test..... Compliance ( ) Non-Compliance ( )
- 20.24 Occupant Head Protection Zone.....Compliance ( ) Non-Compliance ( )
- B2 General Requirements of a Remounted Ambulance.....Compliance ( ) Non-Compliance ( )
- B3 Structural Integrity.....Compliance ( ) Non-Compliance ( )
- B4 Material Changes.....Compliance ( ) Non-Compliance ( )
- B4.1 Seats, Seat Belts, Occupant Restraints.....Compliance ( ) Non-Compliance ( )
- B4.2 Compartment Materials.....Compliance ( ) Non-Compliance ( )
- B4.3 Exterior Lights.....Compliance ( ) Non-Compliance ( )
- B4.4 Body Door Components.....Compliance ( ) Non-Compliance ( )
- B5 Certification of Remount.....Compliance ( ) Non-Compliance ( )
- B5.2 Any Non-Compliance Conditions.....Compliance ( ) Non-Compliance ( )
- B5.3 Testing by Professional Engineer.....Compliance ( ) Non-Compliance ( )
- B5.4 Testing by Contractor.....Compliance ( ) Non-Compliance ( )
- B5.5 Oxygen system pressure test.....Compliance ( ) Non-Compliance ( )

**PART II – NON-COMPLIANCE DETAILS**

Provide sub-section number and provide details. Attach additional information to the Checklist as required.

**PART III – Components and options supplied by Contractor at time of delivery**

In this area Contractors are to list all components and options supplied on unit.

Attach additional information to the Checklist as required.

**PART IV - CONTRACTOR'S COMPLIANCE CERTIFICATION**

**Contractor's Name:** \_\_\_\_\_

I certify that this Annex to Version 7.0 of the 'Ontario Provincial Land Ambulance & Emergency Response Vehicle Standard' has been completed accurately and that all areas of non-compliance have been identified.

**Company Officer:**

\_\_\_\_\_

(Print Name)

\_\_\_\_\_

(Signature)

\_\_\_\_\_

(Date)

\_\_\_\_\_

(Notarized, required for ambulance model certification only)

\_\_\_\_\_

(Date)

**PART V- INDIVIDUAL AMBULANCE DETAILS**

**Vehicle Identification Number:** \_\_\_\_\_

**MOH Compliance Certificate Number:** \_\_\_\_\_

**Date of Completion (final inspection):** \_\_\_\_\_

**Name of Purchaser:** \_\_\_\_\_

## ANNEX E - ERV COMPLIANCE CHECKLIST

### PART I – COMPLIANCE DETAILS

To confirm compliance with Annex A of the *Standard* this Checklist is to be completed and accompany the letter of certification by the Contractor for each unit. Compliance or non-compliance with each requirement will be noted by (X). In instances where any non-compliance is noted, within a section the details of the non-compliance will be provided in the Part II including the sub-section number.

**A3. General Requirements** .....Compliance ( ) Non-Compliance ( )

**A4. Exterior Identification** .....Compliance ( ) Non-Compliance ( )

**A5. Emergency Warning System** .....Compliance ( ) Non-Compliance ( )

A6. 2-Way Radio Installations .....Compliance ( ) Non-Compliance ( )

**A6.5 Installation of radio equipment**.....Compliance ( ) Non-Compliance ( )

**A7. Storage**.....Compliance ( ) Non-Compliance ( )

**A8. Interior signs and labels**.....Compliance ( ) Non-Compliance ( )

**A9. Certification of an ERV** .....Compliance ( ) Non-Compliance ( )

### PART II – NON-COMPLIANCE DETAILS

Provide sub-section number and provide details. Attach additional information to the Checklist as required.

### PART III – Components and options supplied by Contractor at time of delivery

List all components and options supplied on unit. Attach additional information to the Checklist as required.

**PART IV - CONTRACTOR’S COMPLIANCE CERTIFICATION**

**Contractor’s Name:** \_\_\_\_\_

I certify that this Annex to Version 7.0 of the ‘Ontario Provincial Land Ambulance & Emergency Response Vehicle Standard’ has been completed accurately and that all areas of non-compliance have been identified.

**Company Officer:**

\_\_\_\_\_

(Print Name)

\_\_\_\_\_

(Signature)

\_\_\_\_\_

(Date)

\_\_\_\_\_

(Notarized, required for ERV vendor certification only)

\_\_\_\_\_

(Date)

**PART V- INDIVIDUAL AMBULANCE DETAILS**

**Vehicle Identification Number:** \_\_\_\_\_

**MOH Compliance Certificate Number:** \_\_\_\_\_

**Date of Completion (final inspection):** \_\_\_\_\_

**Name of Purchaser:** \_\_\_\_\_